

ENERGY RECOVERY VENTILATOR

VENMAR AVS DUO 1.9

Part #45700 Canada/US

117 to 180 CFM (0.4 in. w.g.)



VB0008

THE «HEALTH CONSCIOUS» SYSTEM THAT IS RIGHT FOR YOU

Designed to provide clean air all year round, the AVS DUO is particularly intended for customers with health concerns. Airborne bacteria, mites and allergens such as dust, pollen and mold are removed. Combined with an optional filter that can be inserted in the unit, the AVS DUO is the perfect ventilation system that provides a healthier indoor environment. The AVS DUO is also the prime choice to work in combination with an air conditioning unit.

- Reversible unit installation
- Improved standard filter performance
- Unique pan design, easier to clean and maintain
- Integrated balancing dampers and pressure taps
- Polymeric enthalpy wheel: recovers heat and humidity
- No drain
- Exclusive HomeShield™ patented defrost system
- SilentSure™ operation
- PSC motor

REPAIRS AND MAINTENANCE

Venmar AVS DUO modular design makes it possible to remove all mechanical parts in less than 5 minutes. The recovery wheel and its driving mechanism are characterized by their simplicity and ease of maintenance. Resorting to proven technologies, the Venmar development team applied the principle of the belt-driven system used in cars and used a shock and vibration-absorbing axle to prevent wear on the motor.

The low power consumption PSC motor is permanently lubricated. Even better, the entire motor subassembly can be removed in less than a minute for easier maintenance. Finally, the electronic circuit board eliminates electromechanical parts, reducing repair time to a minimum.

WARRANTY

The Venmar AVS DUO is fully protected by a 5-year warranty including the energy recovery thermal wheel. We are so confident in our product that we also offer a 90-day in-home warranty on parts and service.

Available at:

Controls

- Built-in electronic circuit board ready to receive one of the following main controls:
 - ULTIMA #40340 - *Ideal for this system*
 - VENTA #40310
 - SUPRA #40320
- One or more of the following optional controls can be added:
 - Humidity Control #11297
 - 20-min. lighted push button #12030
 - 60-min. mechanical timer #00910
 - 20/40/60-minute push button #03364
 - Wireless 20-minute remote control #03366

Options

- Complete line of registers and diffusers
- Electric duct heater
- Filters:
 - Charcoal #03315
 - Pleated #03316
 - Electronic #03314

HomeShield™ Defrosting System

The AVS DUO uses a unique defrosting method. No negative pressure is created by air exhausted to the outside, as the air is recirculated into the house, thus avoiding any backdraft from the chimney. Moreover, this defrosting method by air circulation ensures that no shortage of air is created for combustion units.

OUTSIDE TEMPERATURE °C	DEFROST CYCLE defrosting min./ operating min.	DEFROST CYCLE	
		WARMER THAN -5	WARMER THAN (23)
-5 TO -15	(23 TO 5)	No defrost	9/60
-15 TO -27	(5 TO -19)		9/32
-27 & LESS	(-19 & LESS)		9/20

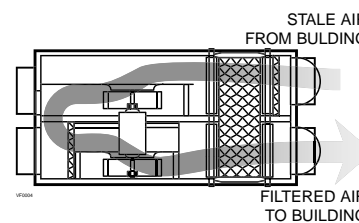

Energy Recovery Wheel

Dimensions: 14" ø x 3-3/4" (36 cm ø x 9.5 cm)
 Weight: 5.5 lbs (2.5 kg)
 Material: Plastic composite impregnated with desiccant
 Type: Thermal wheel
 Warranty: 5-year warranty

Requirements and Standards

- Complies with the UL 1812 requirements regulating the installation of Heat Recovery Ventilators.
- Complies with the CSA C22.2 #113 Standard applicable to ventilators.
- Complies with the CSA C444 requirements regulating the installation of Energy Recovery Ventilators.
- Technical data was obtained from published results of tests relating to CSA C439 Standards.
- HVI certified.

Dimensions and Service Clearances: Venmar AVS DUO 1.9

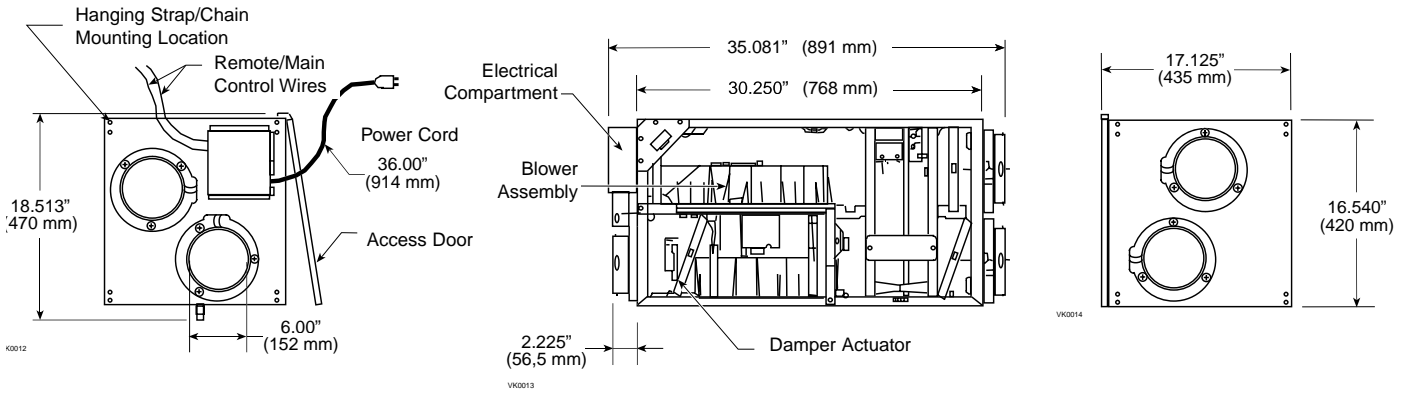

Ventilation Performance

EXT STATIC PRESSURE	NET SUPPLY AIR FLOW			GROSS AIR FLOW						
	Pa	in.w.g.	l/s	cfm	m ³ /h	SUPPLY		EXHAUST		
25	.1	97	206	349	98	208	353	110	233	396
50	.2	95	202	342	96	204	346	106	224	382
75	.3	89	189	320	90	191	324	100	211	360
100	.4	85	180	306	86	182	310	94	199	338
125	.5	80	169	288	81	171	292	89	189	320
150	.6	74	157	266	75	159	270	81	173	292
175	.7	65	138	234	66	139	238	73	156	263
200	.8	56	119	202	57	120	205	59	125	212
225	.9	34	71	122	34	72	122	26	56	94

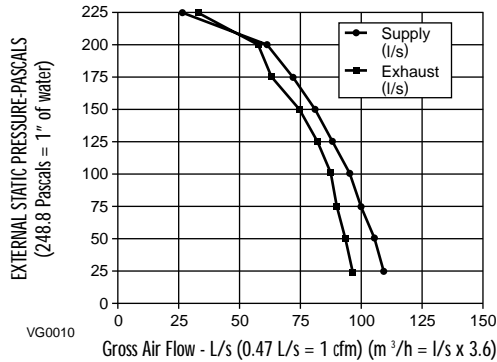

Energy Performance

SUPPLY TEMPERATURE		NET AIR FLOW			POWER CONSUMED WATTS	SENSIBLE RECOVERY EFFICIENCY	APPARENT SENSIBLE EFFECTIVENESS	LATENT RECOVERY/MOISTURE TRANSFER
C°	F°	l/s	cfm	m ³ /h				
HEATING								
0	+32	56	119	202	156	71	81	0.56
0	+32	84	178	302	230	65	72	0.46
0	+32	---	---	---	---	---	---	---
-25	-13	51	108	184	189	66	82	0.69
-25	-13	---	---	---	---	---	---	---
COOLING								
+35	+95	55	117	198	151	TOTAL RECOVERY EFFICIENCY		
+35	+95	---	---	---	---	69		

NOTE: All specifications are subjected to change without notice.

Specifications and Ratings

- Model: Venmar AVS DUO 1.9
- Part Number: #45700 Canada/US
- Total Assembled Weight
(Including energy recovery wheel): 68 lbs (31 Kg)
- Supply Air Duct Connections: 6" (15.24 cm) diameter
- Exhaust Air Duct Connections: 6" (15.24 cm) diameter
- Filters: 20 ppi washable reticulated foam:
-15.375" x 7.125" x 0.75" (39 x 18 x 1.9 cm)

- Cabinet: 20 ga. pre-painted steel
- Insulation: 1" (2.54 cm) aluminium foil faced fiberglass, 0.825" (2.10 cm) expanded polystyrene
- Mounting: suspension by chains and springs
- Supply & Exhaust Blower Motor: 1 motor
 - Protection type: Thermally protected
 - Insulation class: B
 - Motor marking: 120 V ac, 60 Hz, 1.7 A, 1040/1300/1630 RPM

- Fan Speed Control: -Low or increased low and high speed.
-Two speeds available for the user.
-Low or increased low speed is selected at the time of installation.
- Unit Electrical Characteristics:

	Volt	Freq	Amperes	Watts
Canada/US	120	60 Hz	2.2	250

Submitted by:			Date:	Project:
Qty:	Model #:	Remarks:		Location:
				Architect:
				Engineer:
				Contractor:



Residential Product Group, 550 Lemire Blvd, Drummondville, QC, Canada J2C 7W9 - Tel.: 1-800-567-3855 Fax: 1-800-567-1715



www.venmar-ventilation.com

01/04

PRODUCT SHEET #90287