



INSTALLATION GUIDE FOR VENMAR AVS UNIT CONSTRUCTO 1.0 HRV AND CONSTRUCTO 1.0 ERV

**Model no.: 41502
(HRV with ports on top)**



VB0069

**Model no.: 41500
(HRV with ports on sides)**



VB0070

**Model no.: 41506
(ERV with ports on top)**



VB0071

**Model no.: 41504
(ERV with ports on sides)**



VB0074

RESIDENTIAL USE ONLY

READ AND SAVE THESE INSTRUCTIONS



06010A rev. G

ABOUT THIS MANUAL

Because of the large amount of models covered by this publication, the illustrations are typical ones. Some details of your unit may be slightly different than the ones shown.

Please take note that this manual uses the following symbols to emphasize particular information:

WARNING

Identifies an instruction which, if not followed, might cause serious personal injuries including possibility of death.

CAUTION

Denotes an instruction which, if not followed, may severely damage the unit and/or its components.

NOTE: Indicates supplementary information needed to fully complete an instruction.

We welcome any suggestions you may have concerning this manual and/or the unit, and we would appreciate hearing your comments on ways to better serve you. Please contact us by phone at 1 800 567-3855.

ABOUT THESE UNITS

LIMITATION

For residential (domestic) installation only. This unit must be installed in accordance with all national and local regulations, building codes and safety codes.

WARNING

TO REDUCE THE RISK OF FIRE, ELECTRIC SHOCK, OR INJURY TO PERSON(S) OBSERVE THE FOLLOWING:

1. Use this unit only in the manner intended by the manufacturer. If you have questions, contact the manufacturer at the address or telephone number listed in the warranty.
2. Before servicing or cleaning the unit, disconnect power cord from electrical outlet.
3. This unit is not designed to provide combustion and/or dilution air for fuel-burning appliances.
4. When cutting or drilling into wall or ceiling, do not damage electrical wiring and other hidden utilities.
5. Do not use this unit with any solid-state speed control device other than following main wall controls: Lite-Touch Constructo, Simple-Touch Constructo or Constructo, and no other optional wall controls than 60-minute crank timer and/or 20-minute lighted push button and/or Dehumidistat.
6. This unit must be grounded. The power supply cord has a 3-prong grounding plug for your personal safety. It must be plugged into a mating 3-prong grounding receptacle, grounded in accordance with the national electrical code and local codes and ordinances. Do not remove the ground prong. Do not use an extension cord.
7. Do not install in a cooking area or connect directly to any appliances.
8. Do not use to exhaust hazardous or explosive materials and vapors.
9. When performing installation, servicing or cleaning these units, it is recommended to wear safety glasses and gloves.
10. Due to the weight of the unit, two installers are recommended to perform installation.

CAUTION

1. To avoid premature clogged filters, turn OFF the unit during construction or renovation.
2. Please read specification label on product for further information and requirements.
3. Be sure to duct air outside – Do not intake / exhaust air into spaces within walls or ceiling or into attics, crawl spaces, or garage.
4. Intended for residential installation only in accordance with the requirements of NFPA 90B (for a unit installed in USA) or Part 9 of the National Building Code of Canada (for a unit installed in Canada).
5. Do not run any air ducts directly above or closer than 2 ft (0.61 m) to any furnace or its supply plenum, boiler, or other heat producing appliance. If a duct has to be connected to the furnace return plenum, it must be connected not closer than 9'10" (3 m) from this plenum connection to the furnace.
6. The ductwork is intended to be installed in compliance with all local and national codes that are applicable.
7. When leaving the house for a long period of time (more than two weeks), a responsible person should regularly check if the unit operates adequately.
8. If the ductwork passes through an unconditioned space (e.g.: attic), the unit must operate continuously except when performing maintenance and/or repair. Also, the ambient temperature of the house should never drop below 18°C (65°F).

TABLE OF CONTENTS

1.0	TYPICAL INSTALLATIONS	4-5
1.1	FULLY DUCTED SYSTEM	4
1.2	CENTRAL DRAW POINT	4
1.3	SIMPLIFIED INSTALLATION	4
1.4	ATTIC INSTALLATION FOR ERV UNITS ONLY	5
2.0	INSTALLATION	5-10
2.1	INSPECT THE CONTENT OF THE BOX	5
2.2	LOCATING THE UNIT	5
2.3	UNIT PREPARATION	5-6
2.4	HOW TO HANG THE UNIT	6
2.5	PLANNING OF THE DUCTWORK	7
2.6	INSTALLING THE DUCTWORK AND REGISTERS	7-8
2.7	CONNECTING THE DUCTS TO THE UNIT	9
2.8	INSTALLING THE TANDEM® TRANSITION KIT	9
2.9	INSTALLING 2 EXTERIOR HOODS	10
3.0	CONTROLS	11-13
3.1	INTEGRATED CONTROL	11
3.2	ELECTRICAL CONNECTION TO OPTIONAL WALL CONTROLS	12-13
4.0	ELECTRICAL CONNECTION TO THE FURNACE	13
5.0	WIRING DIAGRAM	14
6.0	BALANCING THE UNIT	15
7.0	CONNECTING THE DRAIN (HRV UNITS ONLY)	16
8.0	SERVICE PARTS	17
9.0	TROUBLESHOOTING	18

1. TYPICAL INSTALLATIONS

Installations may vary according to the type of unit and the ports configuration (top or sides). Use the following illustrations as guidelines to help you decide on how the unit will be installed.

All the units should be hung from the joists.

In every case, bathroom fans and a range hood should be used to exhaust stale air. Also, for homes with more than one level, we recommend one exhaust register at the highest level.

There are 3 installation methods: Fully ducted, Central Draw Point and Simplified Installation.

NOTE: An electrical outlet has to be available within 3 feet of the unit.

1.1 FULLY DUCTED SYSTEM (PRIMARYLY FOR HOMES WITH RADIANT HOT WATER OR ELECTRIC BASEBOARD HEATING.)

Stale air coming from the registers located at the highest level of the house is exhausted to the outside. Fresh air from outside is filtered and supplied by the register located in the lowest liveable level.

Homes with more than one level require at least one exhaust register at the highest level.

See figure at right.

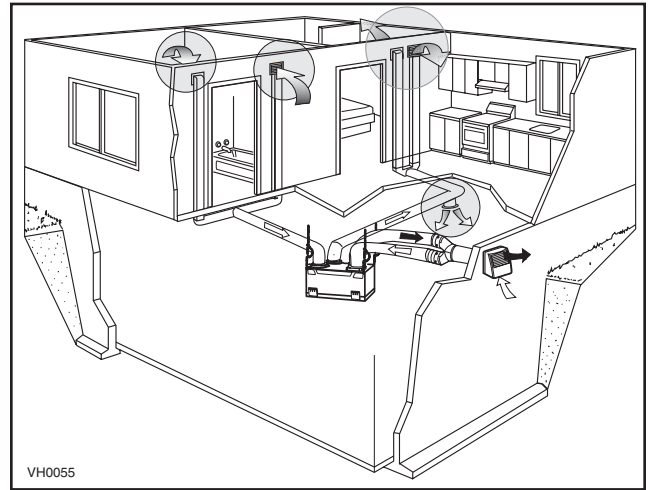

1.2 CENTRAL DRAW POINT (CONNECTION TO A FORCED AIR SYSTEM.)

Stale air coming from the registers located at the highest level of the house is exhausted to the outside. Fresh air from outside is filtered and supplied to the return (plenum) or the supply duct of the forced air unit. See figure at right.

For this type of installation, it is not essential that the forced air system blower runs when the unit is in operation, but we recommend it.

NOTE: Home with multiple forced air systems should have one unit on each system.

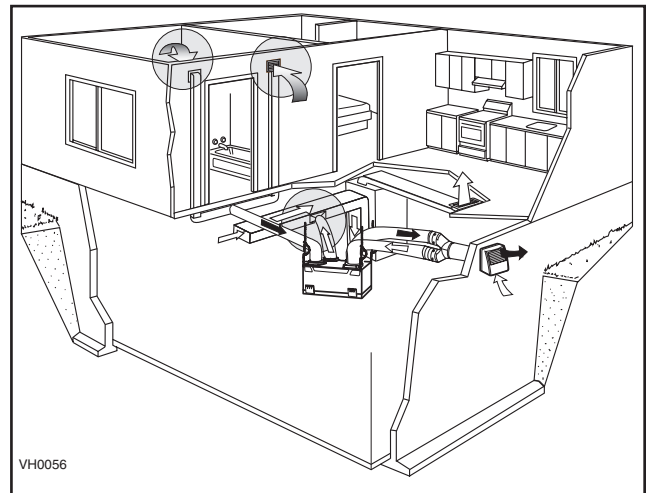

1.3 SIMPLIFIED INSTALLATION (CONNECTION TO A FORCED AIR SYSTEM)

Stale air is exhausted to the outside. Fresh air from outside is filtered and supplied to the return (plenum) or the supply duct of the forced air unit. See figure at right.

To avoid cross-contamination and achieve the highest efficiencies, the forced air system blower must always be ON.

NOTE: Home with multiple forced air systems should have one unit on each system.

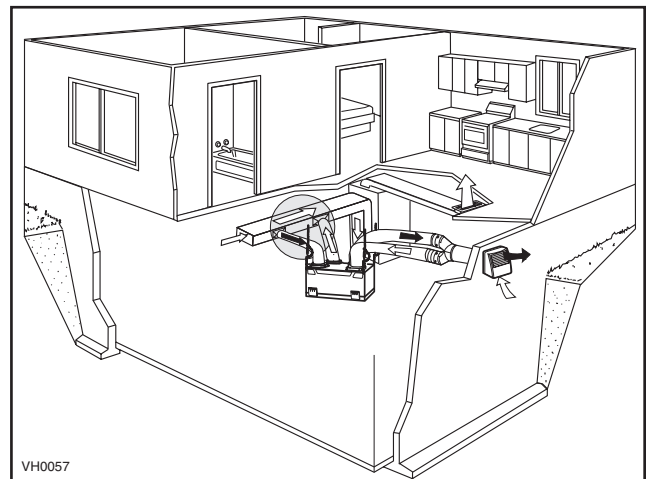

1. TYPICAL INSTALLATIONS (CONT'D)

1.4 ATTIC INSTALLATION FOR ERV UNITS ONLY

All 3 types of installations can be used in the attic (Fully ducted system, Central Draw Point or Simplified). The example shown below is a Simplified installation (connection to a forced air system).

CAUTION

Due to the potential temperature difference between the attic and the rest of the house, all unit ducts must be insulated.

CAUTION

The attic temperature must always be above 0°C (32°F).

Stale air is exhausted to the outside. Fresh air from outside is filtered and supplied to the return (plenum) of the forced air unit. See figure at right.

To avoid cross-contamination and achieve the highest efficiencies, the forced air system blower must always be ON.

NOTE: Home with multiple forced air systems should have 1 unit on each system.

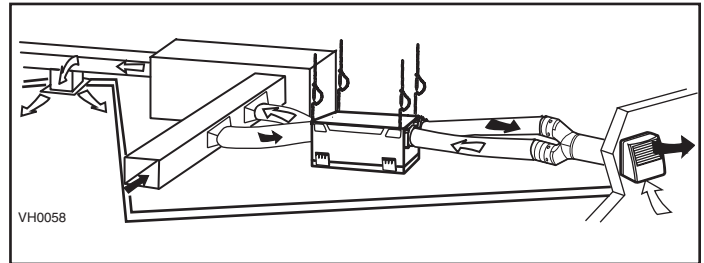

2. INSTALLATION

2.1 INSPECT THE CONTENTS OF THE BOX

- Inspect the exterior of the unit for shipping damage. Ensure that there is no damage to the door, door latches, power cord, etc.
- Remove and discard the 2 transport brackets (A) and open the door. Discard the styrofoam fillers (ERV units only) and remove the hardware kit from the unit. Inspect the interior of the unit for damage. Ensure that heat or energy recovery core, core filters, insulation, dampers, etc. are all intact.

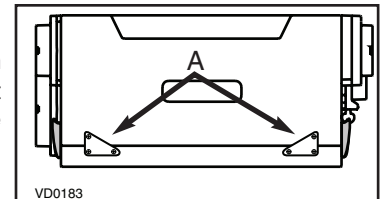

2.2 LOCATING THE UNIT

Choose an appropriate location for the unit.

- Within an area of the house where the ambient temperature is between 10°C (50°F) and 65°C (149°F) (basement, furnace room, closet, etc.).
- So as to provide easy access to the interior of the unit, for maintenance.
- Close to an exterior wall, so as to limit the length of the insulated flexible duct to and from the unit.
- Away from hot chimneys and other fire hazards.
- Allow for a power source (standard 3-prong grounding outlet).
- For HRV units ONLY: Close to a drain. If no drain is close by, use a pail to collect run-off.

2.3 UNIT PREPARATION

Both HRV and ERV units are equipped with 2 ports having integrated balancing damper. Turn the thumb screw (A) **clockwise** to manually open and adjust the damper (B).

HRV UNITS: Set the Fresh air to building port to wide open position, and adjust the Exhaust air to outside port to 3rd notch.

NOTE: If the unit need to be balanced, adjust the damper of the Exhaust air to outside port to wide open position. See *Section 6*.

ERV UNITS: Set both Fresh air to building port and Exhaust air to outside port to wide open position.

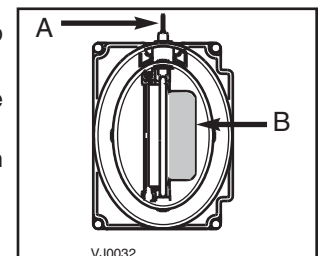

Port with integrated balancing damper - Top view

2. INSTALLATION (CONT'D)

2.3 UNIT PREPARATION (CONT'D)

The door latches location can be changed from sides to front of the unit, according to the installation needs.

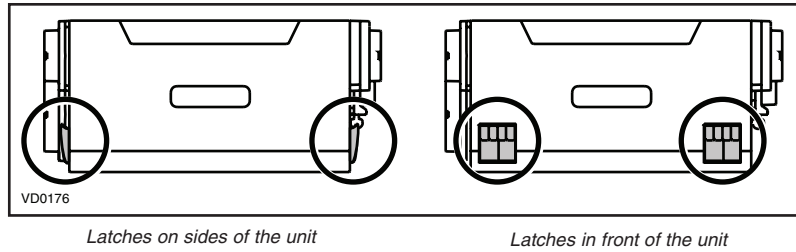

To do so, turn the unit upside down. Open the latches and unscrew them from the unit. Install the latches on their new locations.

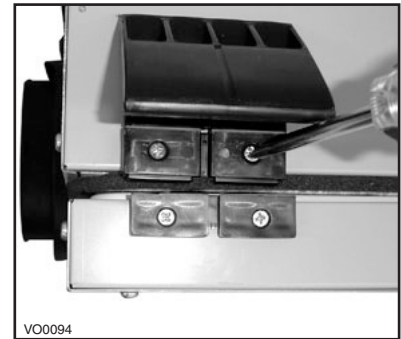
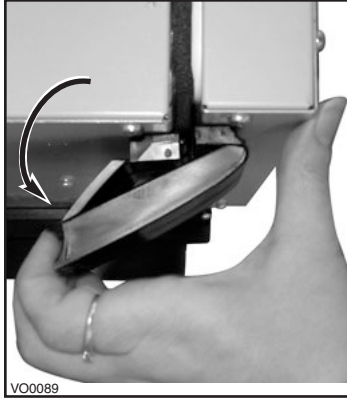

2.4 HOW TO HANG THE UNIT

Hang the unit with the 4 chains, hooks and springs provided.

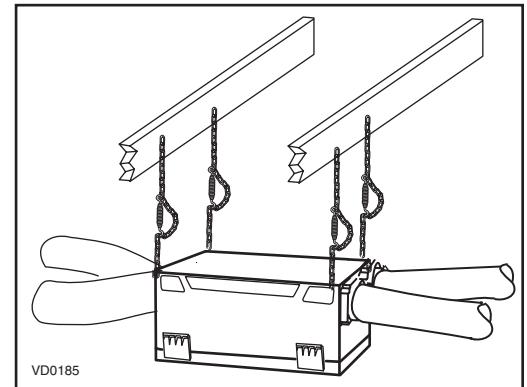
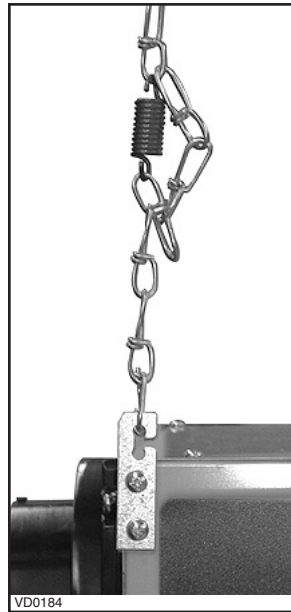

CAUTION
Make sure the unit is level.

If there is not enough space on top of the unit, slightly bend the hooks and install them lower on the unit. See figure beside.

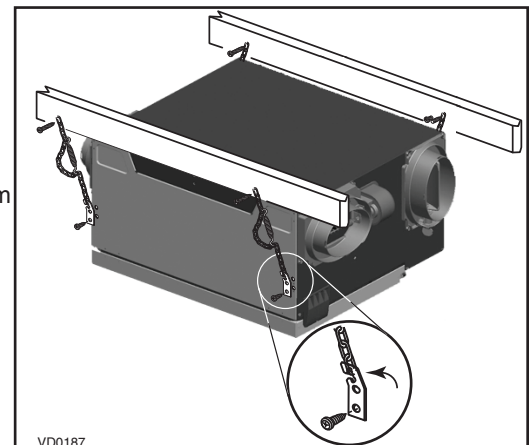

2. INSTALLATION (CONT'D)

2.5 PLANNING OF THE DUCTWORK

- Keep it simple. Plan for a minimum of bends and joints.
- Keep the length of insulated ducts to a minimum.
- Do not ventilate crawl spaces or cold rooms. Do not attempt to recover the exhaust air from a dryer or a range hood. This would cause clogging of the filters and recovery module.
- If the house has two floors or more, be sure to plan for at least one exhaust register on the highest lived-in level.

2.6 INSTALLING THE DUCTWORK AND REGISTERS

⚠ WARNING

Never install a stale air exhaust register in a closed room where a combustion device operates, such as a gas furnace, a gas water heater or a fireplace.

2.6.1 FULLY DUCTED SYSTEM (AS ILLUSTRATED IN SECTION 1.1)

Stale air exhaust ductwork

- Install the stale air exhaust registers where the contaminants are produced: kitchen, living room, etc. Position the registers as far from the stairway as possible and in such a way that the air circulates in all the lived-in spaces in the house.
- If a register is installed in the kitchen, it must be located at least 4 feet (1.2 m) from the range.
- Install the registers 6 to 12 inches (152 to 305 mm) from the ceiling on an interior wall OR install them in the ceiling.

Fresh air distribution ductwork

- Install the fresh air distribution registers in bedrooms, dining rooms, living room and basement.
- Keep in mind that the fresh air registers must be located as far as possible from the stale air registers.
- Install the registers in the ceiling OR 6 to 12 inches (152 to 305 mm) from the ceiling on an interior wall. The duct length should be at least 15' (4.6 m). (The fresh air will then flow through the room and mix with room air, ensuring a continuous renewed airflow.)
- If a register must be floor installed, direct the airflow up the wall.

2.6.2 CENTRAL DRAW POINT SYSTEM (AS ILLUSTRATED IN SECTION 1.2)

Stale air exhaust ductwork

Same as for Fully Ducted System, described on point 2.6.1)

Fresh air distribution ductwork

⚠ WARNING

When performing duct connections, always use approved tools and materials. Respect all corresponding laws and safety regulations. Please refer to your local building code.

CAUTION

When performing duct connections to the furnace supply duct, this duct must be sized to support the additional airflow produced by the HRV/ERV. Also, use a steel duct.

There are 2 methods for connecting the unit to the furnace/air handler:

Method 1: Supply side connection

- Cut an opening into the furnace supply duct at least 18 inches (0.5 m) from the furnace/air handler.
- Connect this opening to the **Fresh air to building** port of the HRV/ERV (use **steel duct**, see figure beside).
- Make sure the HRV/ERV duct form an elbow inside the furnace/air handler ductwork.
- If desired, interlock (synchronize) the furnace/air handler blower operation (see *Section 4*).

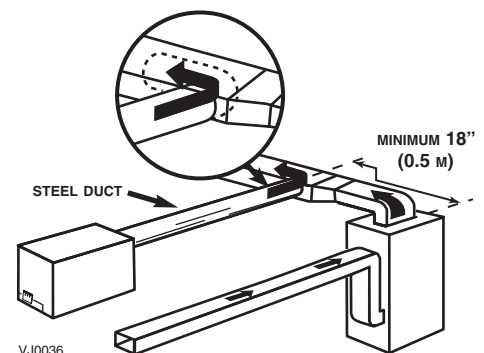

Method 2: Return side connection

- Cut an opening into the furnace return duct not less than 10 feet (3.1 m) from the furnace/air handler (A+B).
- Connect this opening to the **Fresh air to building** port of the HRV/ERV (see figure beside).

NOTE: For Method 2, it is not essential that the furnace/air handler runs when the unit is operation, but we recommend it. If desired, interlock (synchronize) the furnace/air handler blower operation (see *Section 4*).

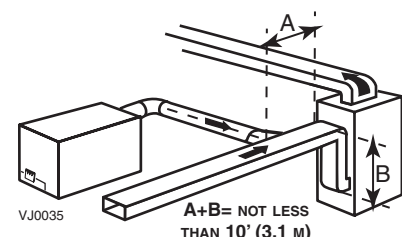

2. INSTALLATION (CONT'D)

2.6 INSTALLING THE DUCTWORK AND REGISTERS (CONT'D)

2.6.3 SIMPLIFIED INSTALLATION (AS ILLUSTRATED IN SECTION 1.3)

⚠ WARNING

When performing duct connections, always use approved tools and materials. Respect all corresponding laws and/or safety regulations. Please refer to your local building code.

CAUTION

When performing duct connections to the furnace supply duct, this duct must be sized to support the additional airflow produced by the HRV/ERV. Also, use a steel duct. For a Return-Return installation, the furnace blower must be in operation when the HRV/ERV is in operation.

There are 2 methods for connecting the unit to the furnace/air handler:

Method 1: Supply-return connection

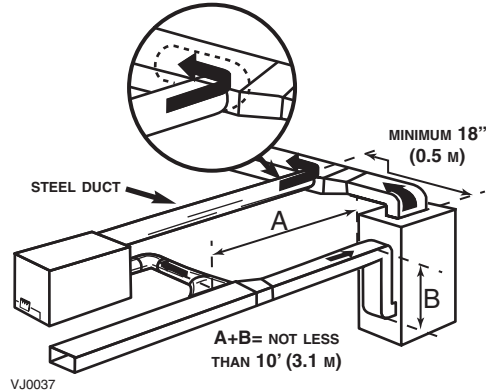

Method 2: Return-return without

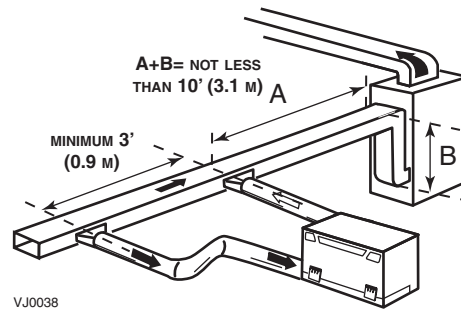

Stale air intake

- Cut an opening into the furnace/air handler return duct not less than 10 feet (3.1 m) from the furnace/air handler (A+B).
- Connect this opening to the **Exhaust air from building** port of the HRV/ERV.

Fresh air distribution

- Same instructions as for Method 1 or Method 2, Section 2.6.2.

For Method 2 (Return-return), make sure there is a distance of at least 3 feet (0.9 m) between the 2 connections to the furnace/air handler.

NOTE: For Method 1, it is not essential to synchronize the furnace blower operation with the unit operation, but we recommend it.

CAUTION

If using Method 2, make sure the furnace/air handler blower operation is synchronized with the unit operation! See **Section 4**.

2. INSTALLATION (CONT'D)

2.7 CONNECTING THE DUCTS TO THE UNIT

Insulated flexible ducts

Use the following procedure for connecting the insulated flexible ducts to the port of the unit (*Exhaust air to outside* and *Fresh air from outside* ports).

CAUTION

Make sure the balancing dampers are set to their appropriate position before connecting the ducts to the ports. See Section 2.3.

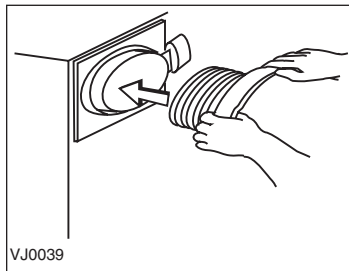

Pull back the insulation to expose the flexible duct.

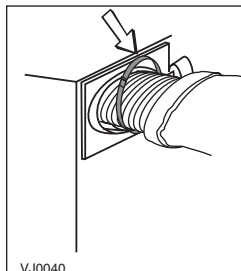

Attach the flexible duct to the port using tie wrap.

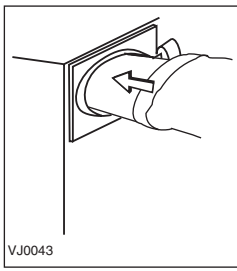

Pull the insulation over the joint and tuck in between the inner and outer rings of the double collar.

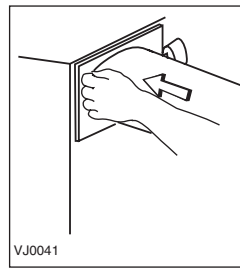

Pull the vapor barrier over the insulation and over the outer ring of the double collar.

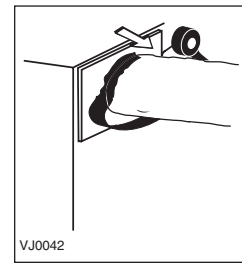

Apply duct tape to the joint making an airtight seal. Avoid compressing the insulation when pulling the tape tightly around the joint. Compressed insulation loses its R value and causes water dripping due to condensation on the exterior surface of the duct.

CAUTION

Make sure the vapor barrier on the insulated ducts does not tear during installation to avoid condensation within the ducts.

Rigid ducts

CAUTION

Do not use screws to connect the rigid ducts to the ports.

Use a small length of flexible duct to connect the rigid duct to the ports in order to avoid vibration transmissions. Use tie-wraps to perform connections.

2.8 INSTALLING THE TANDEM® TRANSITION* KIT

The joist opening needed to install the Tandem® transition must be 9 3/4" minimum. The maximum height of the Tandem® transition is 8 3/4".

To connect the insulated flexible ducts to the Tandem® transition (*Exhaust air to outside* and *Fresh air from outside*), follow the instructions included with the Tandem® transition kit (part #14690).

*Patent Pending.

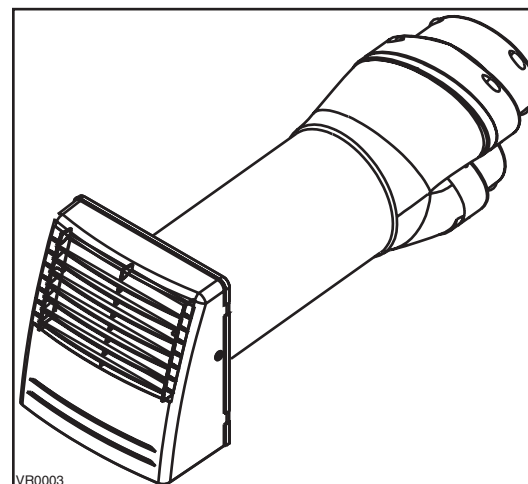

Tandem® transition kit

NOTE: If the joist are perpendicular to the ducts, or if the connection to the exterior hood is in a limited area, the installation will need 2 exterior hoods instead of one. See next Section 2.9 INSTALLING 2 EXTERIOR HOODS.

2. INSTALLATION (CONT'D)

2.9 INSTALLING 2 EXTERIOR HOODS

Choose an appropriate location to install the exterior hoods:

- There must be a minimum distance of 6 feet (1.8 m) between the hoods to avoid cross-contamination
- There must be a minimum distance of 18 inches (457 mm) from the ground

Make sure the intake hood is at least 6 feet (1.8 m) away from the following:

- Dryer exhaust, high efficiency furnace vent, central vacuum vent
- Gas meter exhaust, gas barbecue grill
- Any exhaust from a combustion source
- Garbage bin and any other sources of contamination

Refer to figure below for connecting insulated ducts to the exterior hoods. An "Anti-gust intake hood" should be installed in regions where a lot of snow is expected to fall.

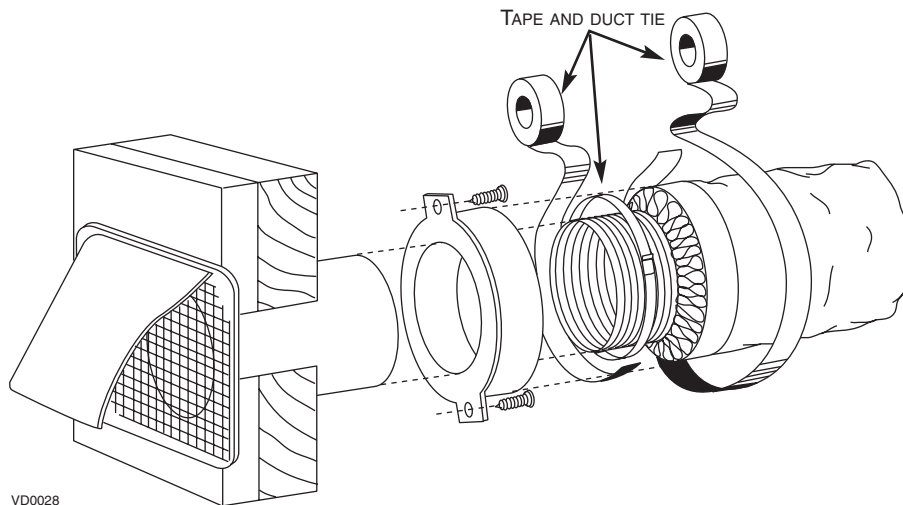
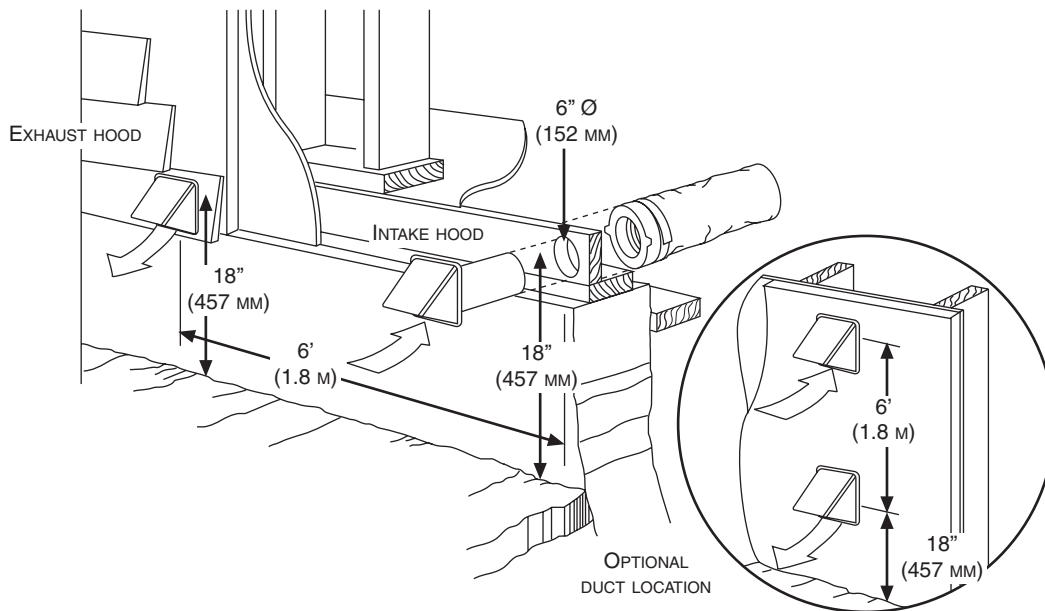

VD0028

3. CONTROLS

3.1 INTEGRATED CONTROL

All units are equipped with an integrated control, located under the unit, in front of the electrical compartment. Use the push button (1) to control the unit. The LED (2) will then shows on which mode the unit is in.

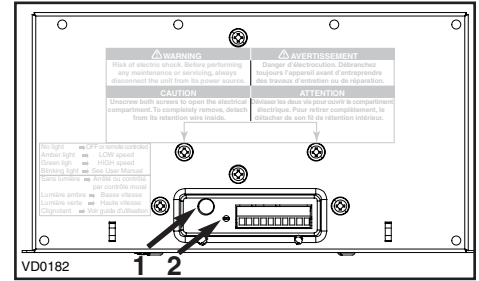

Refer to table below to see how to operate the unit using its integrated control.

PRESS ON PUSH BUTTON	LED COLOR	RESULTS
ONCE	AMBER	UNIT IS ON LOW SPEED
TWICE	GREEN	UNIT IS ON HIGH SPEED
THREE TIMES	NO LIGHT	UNIT IS OFF

If a problem occurs during the unit operation, its integrated control LED (2) will blink. The color of the blinking light depends on the type of error detected. Refer to *Section 9 Troubleshooting* on last page for further details.

3.1.1 BOOT SEQUENCE

The unit boot sequence is similar to a personal computer boot sequence. Each times the unit is plugged after being unplugged, or after a power failure, the unit will perform a 30-second booting sequence before starting to operate. During the booting sequence, the integrated control LED will light GREEN or AMBER for 5 seconds, and then will shut off for 2 seconds. After that, the LED will light RED for the rest of the booting sequence. During this RED light phase, the unit is checking and resetting the motorized damper position. Once the motorized damper position completely set, the RED light turns off and the booting sequence is done.

NOTE: No command will be taken until the unit is fully booted.

3. CONTROLS (CONT'D)

3.2 ELECTRICAL CONNECTION TO OPTIONAL WALL CONTROLS

For more convenience, this unit can also be controlled using an optional main wall control.

NOTES: 1. The integrated control must be turned OFF to use an optional main control.

2. If an optional auxiliary control is used, if activated, this auxiliary control will override the optional main control.

⚠ WARNING

Always disconnect the unit before making any connections. Failure in disconnecting power could result in electrical shock or damage of the wall control or electronic module inside the unit.

CAUTION

Never install more than one optional main wall control per unit. Make sure that the wires do not short-circuit between themselves or by touching any other components on the wall control. Avoid poor wiring connections. To reduce electrical interference (noise) potential, do not run wall control wiring next to control contactors or near light dimming circuits, electrical motors, dwelling/building power or lighting wiring, or power distribution panel.

Use the terminal connector included in the installation kit to perform the electrical connection for main and optional wall controls. Check if all wires are correctly inserted in their corresponding holes in the terminal block. (A wire is correctly inserted when its orange receptacle is lower than another one without wire. On picture beside, wire **A** is correctly inserted, but not wire **B**.)

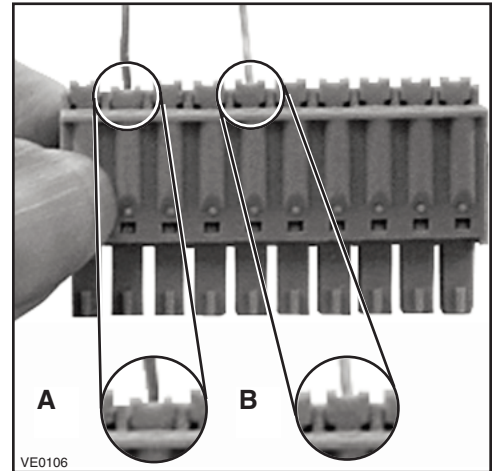

3.2.1 ELECTRICAL CONNECTION TO LITE-TOUCH CONSTRUCTO OR SIMPLE-TOUCH CONSTRUCTO MAIN WALL CONTROLS

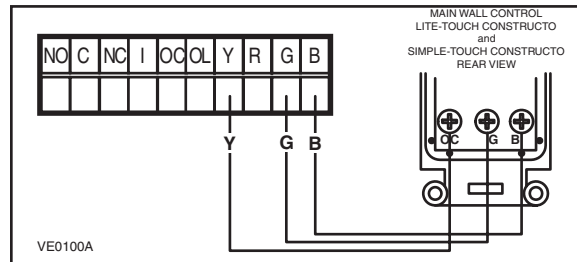

3.2.2 ELECTRICAL CONNECTION TO CONSTRUCTO MAIN WALL CONTROL

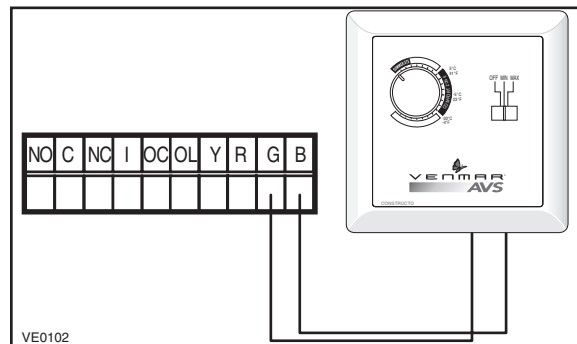

3. CONTROLS (CONT'D)

3.2 ELECTRICAL CONNECTION TO OPTIONAL WALL CONTROLS (CONT'D)

3.2.3 ELECTRICAL CONNECTION TO OPTIONAL AUXILIARY WALL CONTROLS

NOTE: If an optional auxiliary wall control is activated and then, the Dehumidistat is being activated, the Dehumidistat will override the auxiliary wall control commands.

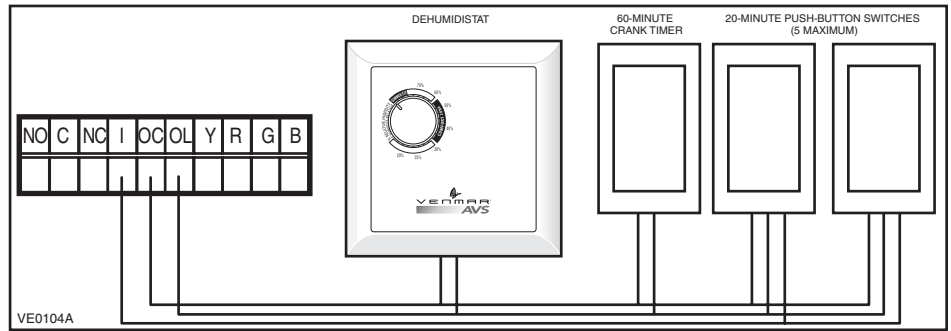

Once the wall control(s) connections have been made, insert the terminal connector in the bottom of the unit, on the electrical compartment front face.

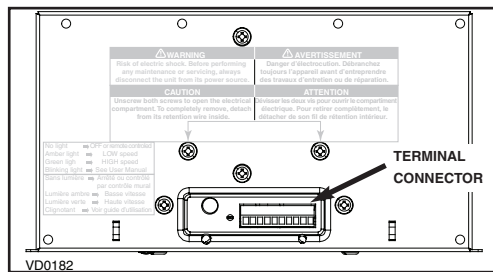

NOTE: For information about the operation of the wall controls, refer to the user guide.

4. ELECTRICAL CONNECTION TO THE FURNACE

⚠ WARNING

Never connect a 120-volt AC circuit to the terminals of the furnace interlock (standard wiring). Only use the low voltage class 2 circuit of the furnace blower control.

For a furnace connected to a cooling system:

On some older thermostats, energizing the «R» and «G» terminals at the furnace has the effect of energizing «Y» at the thermostat and thereby turning on the cooling system. If you identify this type of thermostat, you must use the ALTERNATE FURNACE INTERLOCK WIRING.

STANDARD FURNACE INTERLOCK WIRING

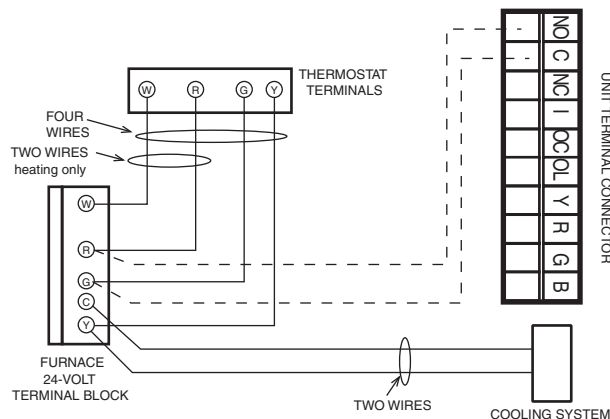

VE0108A

ALTERNATE FURNACE INTERLOCK WIRING

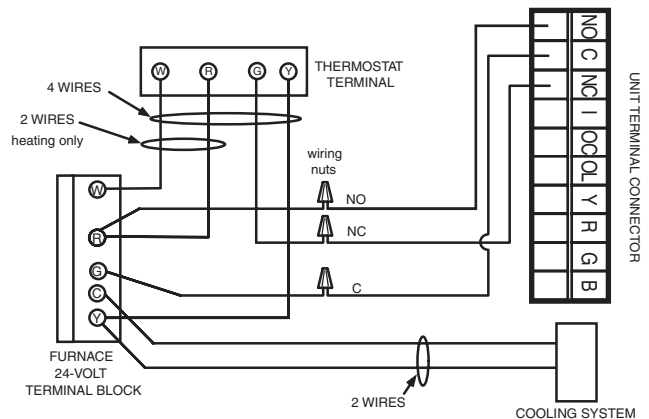

5. WIRING DIAGRAM

⚠ WARNING

Risk of electrical shocks. Before performing any maintenance or servicing, always disconnect the unit from its power source.

CAUTION

Never change both Ref 1 and Ref 2 configurations, only one configuration can be changed at the same time. If Ref 1 and Ref 2 configurations are changed, Medium and Low speed will be reversed.

LOGIC DIAGRAM

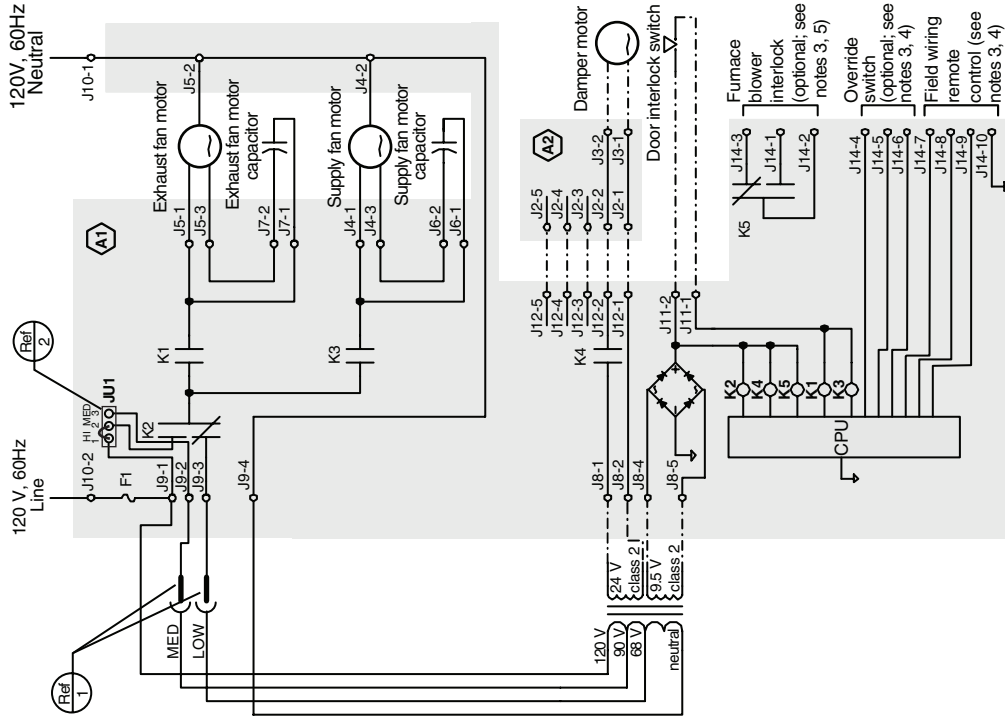

WIRING DIAGRAM

- NOTES**
1. For continued fire protection. Use specified UL listed/CSA Certified line fuse.
 2. If any of the original wire, as supplied, must be replaced, use the same equivalent wire.
 3. Field wiring must comply with applicable codes, ordinances and regulations.
 4. Remote controls (Class 2 circuit) available, see instruction manual.
 5. Furnace fan circuit must be class 2 circuit only.



Critical characteristic.

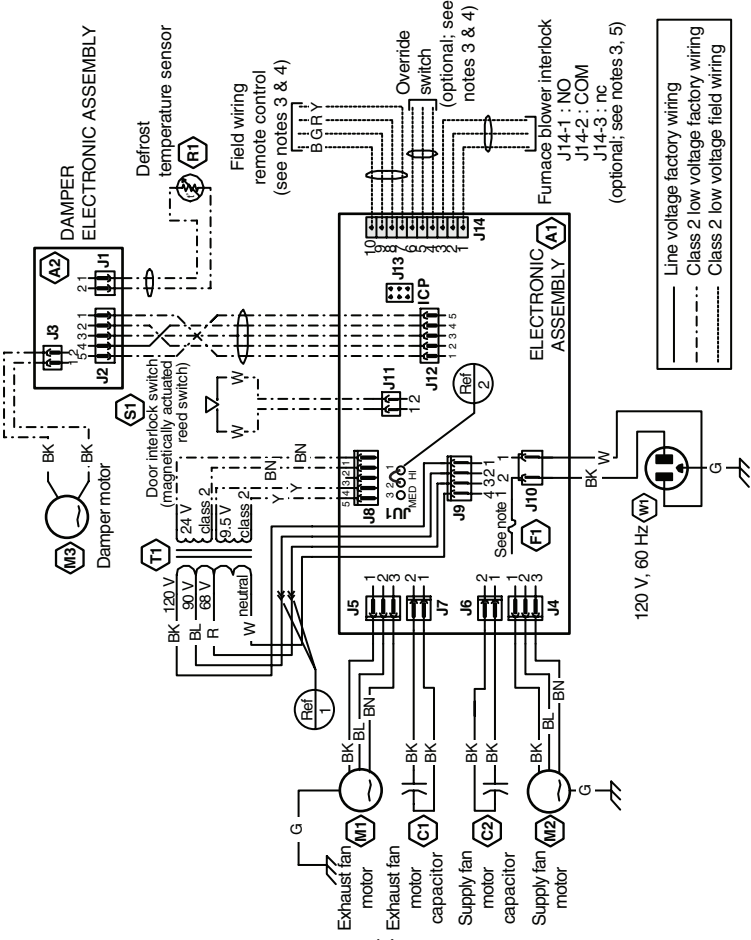

COLOR CODE

BK	BLACK
BL	BLUE
BN	BROWN
G	GREEN
R	RED
W	WHITE
Y	YELLOW
nc	no connection

FAN MOTORS SPEED SELECTION

SETTING	Ref 1	Ref 2	FAN SPEEDS (Voltage)
Factory shipped			Low (68) - High (120)
Med-High select			Med (90) - High (120)
Low-Med select			Low (68) - Med (90)
Not recommended			Med - Low

6. BALANCING THE UNIT

To avoid balancing, the difference between stale air ducts total length and fresh air ducts total length must not exceed 50 ft. However, even if the stale air ducts and fresh air ducts lengths are almost equal, your local building codes may require balancing the unit.

If the unit does not need to be balanced, shut all the pressure taps (located on the unit door) with the small plastic plugs included in the hardware kit.

6.1 WHAT YOU NEED TO BALANCE THE UNIT

- A magnehelic gauge capable of measuring 0 to 0.5 inch of water (0 to 125 Pa) and 2 plastic tubes.
- The balancing chart located on the unit door.

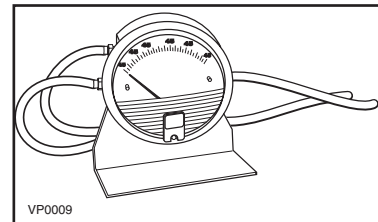

6.2 PRELIMINARY STAGES TO BALANCE THE UNIT

- Seal all the unit ductwork with tape. Close all windows and doors.
- Turn off all exhaust devices such as range hood, dryer and bathroom fans.
- Make sure the integrated balancing dampers are fully open. Turn the thumb screw (A) **clockwise** to manually open the dampers. Both are located on the Exhaust air to outside port and on Fresh air to building port.
- Make sure all filters are clean (if it is not the first time you balance the unit).

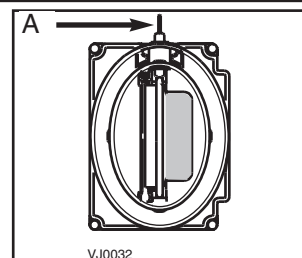

Port with integrated balancing damper - Top view

6.3 BALANCING PROCEDURE

1. Set the unit to high speed.

Make sure that the furnace/air handler blower is ON if the installation is in any way connected to the ductwork of the cold air return. If not, leave furnace/air handler blower OFF. If the outside temperature is below 0°C / 32°F, make sure the unit is not running in defrost while balancing. (By waiting 10 minutes after plugging the unit in, you are assured that the unit is not in a defrost cycle.)

2. Place the magnehelic gauge on a level surface and adjust it to zero.

3. Connect tubing from gauge to EXHAUST air flow pressure taps (see diagram beside).

Be sure to connect the tubes to their appropriate *high/low* fittings. If the gauge drops below zero, reverse the tubing connections.

NOTE: It is suggested to start with the exhaust air flow reading because the exhaust has typically more restriction than the fresh air, especially in cases of fully ducted installations or source point ventilation. Place the magnehelic gauge upright and level. Record equivalent AIR FLOW of the reading according to the balancing chart.

4. Move tubing to FRESH air flow pressure taps (see diagram). Adjust the fresh air flow balancing damper until the fresh air flow is approximately the same as the EXHAUST air flow. If fresh air flow is less than exhaust air flow, then go back and adjust the exhaust balancing damper to equal the fresh air flow.

5. Secure both dampers thumb screw in place with tape.

6. Write the required air flow information on a label and stick it near the unit for future reference (date, maximum speed air flows, your name, phone number and business address).

NOTE: The unit is considered balanced even if there is a difference of ± 10 cfm (or ± 5 l/s or 17 m³/h) between the two air flows.

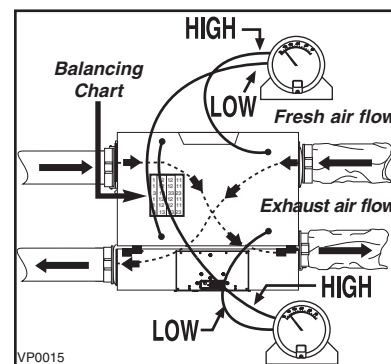

7. CONNECTING THE DRAIN (HRV UNITS ONLY)

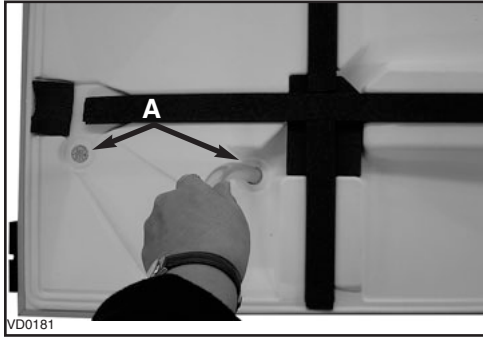

From the inner side of the unit door, using the provided drain tube, punch out both drain holes (A).

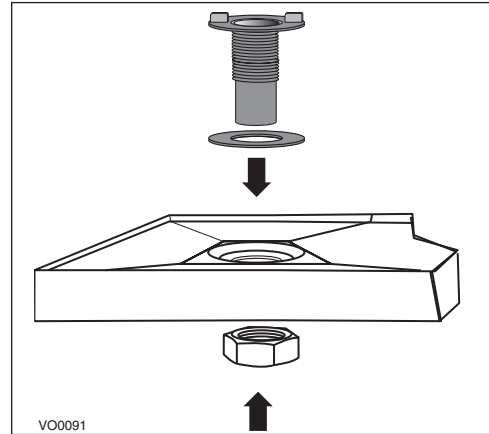

In order to keep the drain pan intact, hand tighten the 2 plastic drain fittings to the unit door using the gaskets and nuts as shown.

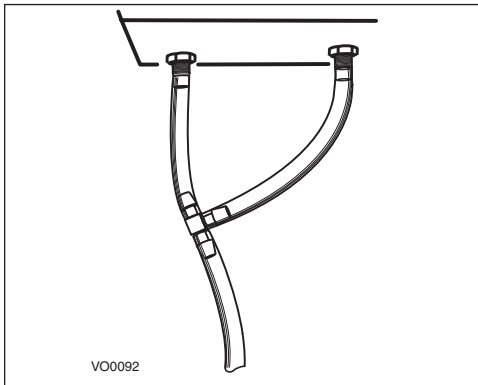

Cut 2 sections of plastic tubing, about 12" (305 mm) long and attach them to each drain fitting. Join the 2 short sections to the "T" junction and main tube as shown.

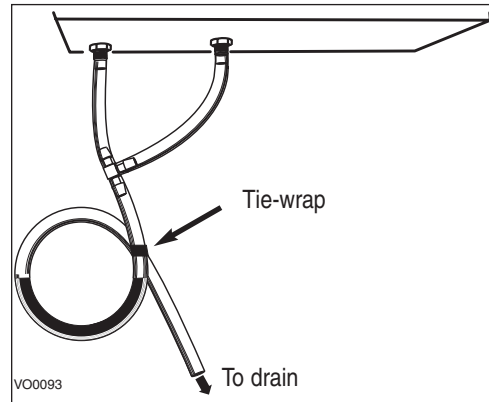

Make a water trap loop in the tube to prevent the unit from drawing unpleasant odors from the drain source. Make sure this loop is situated **BELOW** the "T" as shown. This will prevent water from being drawn back up into the unit in case of negative pressure. Run the tube to the floor drain or to an alternative drain pipe or pail. Be sure there is a slight slope for the run-off.

8. SERVICE PARTS

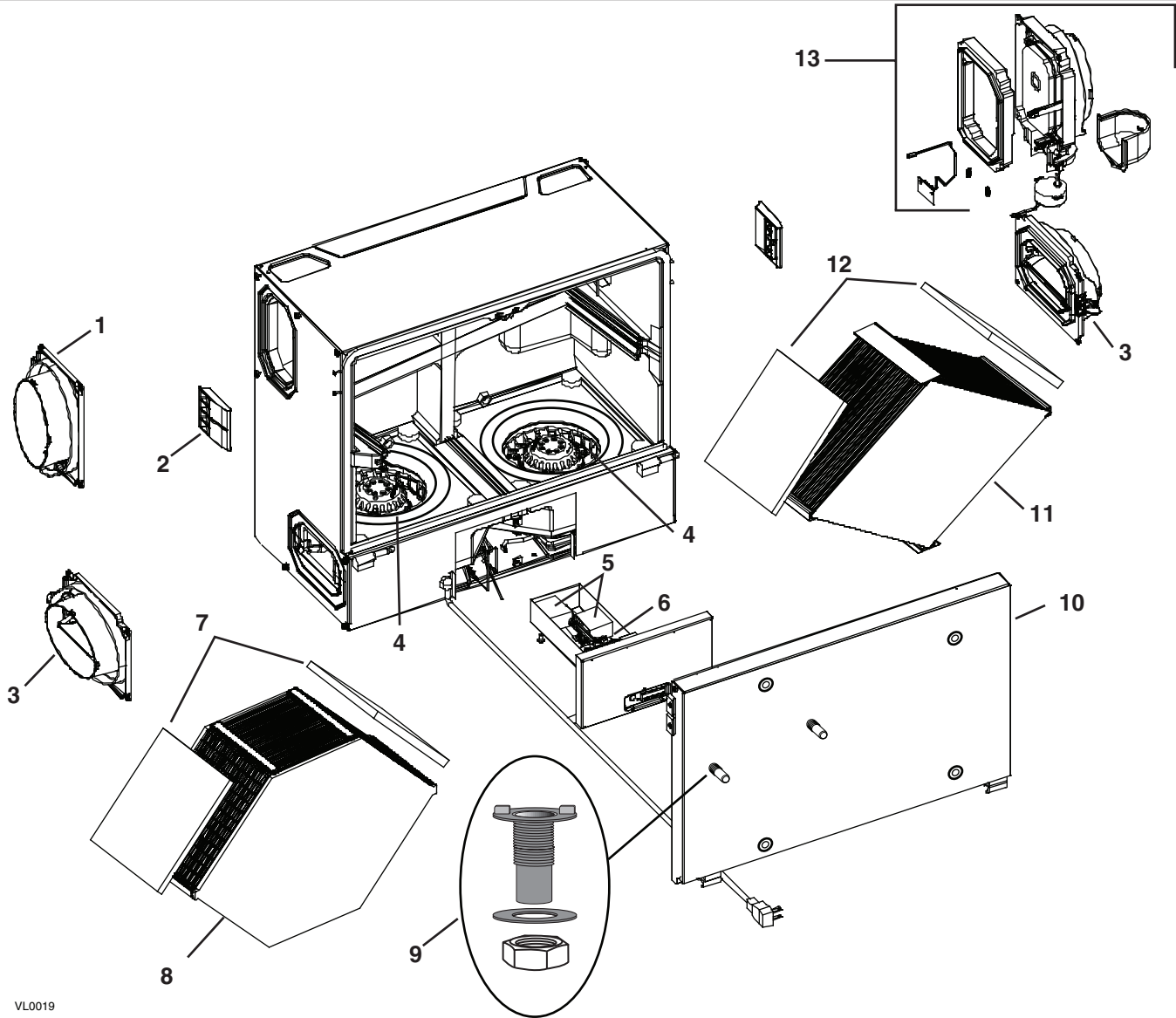

VL0019



ITEM	DESCRIPTION	PART NUMBER	41500 HRV	41502 HRV	41504 ERV	41506 ERV
			PORTS ON SIDES	PORTS ON TOP	PORTS ON SIDES	PORTS ON TOP
1	OVAL PORT (FITS 5" DIAMETER DUCTS)	16040	1	1	1	1
2	DOOR LATCH WITH SCREWS	16035	2	2	2	2
3	OVAL PORT WITH INTEGRATED BALANCING DAMPER	16041	2	2	2	2
4	MOTOR & WHEEL ASSEMBLY (MOTOR CAPACITOR AND INLET RING INCLUDED)	16024	2	2	2	2
5	CAPACITOR 3 μ F	17024	2	2	2	2
6	ELECTRONIC BOARD	16038	1	1	1	1
7	ERV FOAM FILTER	16031	N/A	N/A	2	2
8	ERV CORE (WITH 2 FILTERS)	16033	N/A	N/A	1	1
9	DRAIN CONNECTOR KIT	03203	1	1	N/A	N/A
10	DOOR ASSEMBLY	16094	1	1	1	1
11	HRV CORE (WITH 2 FILTERS)	16034	1	1	N/A	N/A
12	HRV FOAM FILTER	16032	2	2	N/A	N/A
13	MOTORIZED DAMPER PORT ASSEMBLY	16029	1	1	1	1
14*	TRANSFORMER	16039	1	1	1	1

* PART NOT SHOWN.

9. TROUBLESHOOTING

If the integrated control LED of the unit is flashing, this means the unit sensors detected a problem. See the table below to know where on the unit the problem occurs.

LED flashes GREEN.	• Thermistor error.	Replace the entire port assembly (fresh air from outside port).
LED flashes AMBER.	• Damper error.	Go to Point 6.
LED flashes RED.	• The door is open and the unit is not unplugged.	Close the door and press once on the integrated control push button to reset the unit.
	• Exhaust motor error.	Go to Point 5.

Problems	Possible causes	You should try this
1. Unit does not work.	•The circuit board may be defective.	<ul style="list-style-type: none"> •Unplug the unit. Disconnect the main control and the optional(s) control(s) (if need be). Jump G and B terminals. Plug the unit back and wait about 10 seconds. If the motors run on high speed and the damper opens, the circuit board is not defective.  <p style="text-align: right; margin-right: 20px;">VE0097</p>
2. The damper actuator does not work.	<ul style="list-style-type: none"> •The damper actuator or the integrated damper port mechanism may be defective •The circuit board may be defective. 	<ul style="list-style-type: none"> •Unplug the unit. Disconnect the main control and the optional controls(s) (if need be). Wait 10 seconds and plug the unit back. Check if the damper opens. If not, use a multimeter and check for 24V AC on J12-1 and J12-2 (in electrical compartment). If there is 24V AC, replace the entire port assembly. NOTE: It is normal to experience a small delay (7-8 seconds) before detecting the 24V AC signal at starting-up. This signal will stay during 17-18 seconds before disappearing. •If there is no 24V AC, replace the circuit board.
3. The wall control does not work OR its indicator flashes.	<ul style="list-style-type: none"> •The wires may be in reverse position. •The wires may be broken. •The wire in the wall OR the wall control may be defective. 	<ul style="list-style-type: none"> •Ensure that the color coded wires have been connected to their appropriate places. •Inspect every wire and replace any that are damaged. •Remove the wall control and test it right beside the unit using another shorter wire. If the wall control works there, change the wire. If it does not, change the wall control.
4. The Dehumidistat does not work OR the 20-minute push-button timer does not work OR its indicator light does not stay on.	<ul style="list-style-type: none"> •The wires may be in reverse position. •The Dehumidistat or push button may be defective. 	<ul style="list-style-type: none"> •Ensure that the color coded wires have been connected to their appropriate places. •Jump the OL and OC terminals. If the unit switch to high speed, remove the Dehumidistat or push button and test it right beside the unit using another shorter wire. If it works here, change the wire. If it doesn't, change the Dehumidistat or the push button.  <p style="text-align: right; margin-right: 20px;">VE0098</p>
5. The supply and/or exhaust motor do not work.	<ul style="list-style-type: none"> •The circuit board may be defective. •The motor(s) may be defective. 	<ul style="list-style-type: none"> •Press on the integrated control push button until the unit turn on low speed (the LED will light AMBER). Using a multimeter, check the voltage on J4-1 and J4-2 (for supply motor), and on J5-1 and J5-2 (for exhaust motor). Refer to the FAN MOTORS SPEED SELECTION table in <i>Section 5 Wiring Diagram</i> to know what the reading must be. Then set the unit on high speed by pressing on the integrated control push button one more time (the LED will light GREEN). Using a multimeter, check the voltage on J4-1 and J4-2 (for supply motor), and on J5-1 and J5-2 (for exhaust motor). Refer to the FAN MOTORS SPEED SELECTION table in <i>Section 5 Wiring Diagram</i> to know what the reading must be. If all the readings correspond to the right voltage values, the circuit board is not defective. If one or both readings are different, change the circuit board. •Using a multimeter, check the ohms value on each motor connectors. For BLUE and BLACK motor wires, the right value is ± 52 ohms. For BLUE and BROWN motor wires, the right value is ± 72 ohms. For BROWN and BLACK motor wires, the right value is ± 124 ohms. If the ohms values are the same, the motor is not defective. Replace the motor capacitor.
6. The defrost cycle does not work (the fresh air duct is frozen OR the fresh air distributed is very cold.	<ul style="list-style-type: none"> •Ice deposits may be hindering the damper operation. •The damper rod or the port damper itself may be broken. •The damper actuator or circuit board may be defective. 	<ul style="list-style-type: none"> •Remove the ice. •Inspect these parts and replace if necessary. •See point 2.
7. The integrated control push button does not work.	•The 30-second boot sequence is not completed.	•See <i>Section 3.1.1 Boot Sequence</i> .