

INSTALLATION MANUAL



VB0100

MODELS

ERV CONSTRUCTO 1.5 QUATTRO

ERV CONSTRUCTO 2.0 QUATTRO

FOR RESIDENTIAL USE ONLY

READ AND SAVE THESE INSTRUCTIONS



About this Manual

This manual uses the following symbols to emphasize particular information:

WARNING

Identifies an instruction which, if not followed, might cause serious personal injuries including possibility of death.

CAUTION

Denotes an instruction which, if not followed, may severely damage the unit and/or its components.

NOTE: Indicates additional information needed to fully complete an instruction.

WARNING

When performing installation, servicing or cleaning the unit, it is recommended to wear safety glasses and gloves.

CAUTION

This unit is intended for residential use only.

TABLE OF CONTENTS

1.	SERVICE	3
	1.1 3-D DRAWING	3
	1.2 SERVICE PARTS ORDERING CHART	3
	1.3 TECHNICAL SUPPORT (FOR TECHNICIANS AND/OR CONTRACTORS ONLY)	4
2.	TECHNICAL DATA	4
	2.1 AIR DISTRIBUTION	4
	2.2 DIMENSIONS	4
	2.3 SPECIFICATIONS	4
3.	DEFROST SETTING VS GEOGRAPHICAL LOCATION	5
4.	TYPICAL INSTALLATIONS	5
	4.1 FULLY DUCTED SYSTEM	5
	4.2 EXHAUST DUCTED SYSTEM (SOURCE POINT VENTILATION)	5
	4.3 SIMPLIFIED (VOLUME VENTILATION)	6
5.	INSTALLATION	6
	5.1 LOCATING AND MOUNTING THE UNIT	6
	5.2 PLANNING THE DUCTWORK	7
	5.3 CALCULATING DUCT SIZE	7
	5.4 INSTALLING THE DUCTWORK AND REGISTERS	8-9
	5.5 CONNECTING THE DUCTS TO THE UNIT	10
	5.6 INSTALLING THE EXTERIOR HOODS	11
6.	CONTROLS	12
	6.1 MAIN CONTROLS	12
	6.2 AUXILIARY CONTROLS	12
	6.3 ELECTRICAL CONNECTION TO LITE-TOUCH CONSTRUCTO AND AUXILIARY CONTROLS	13
	6.4 ELECTRICAL CONNECTION TO THE FURNACE (OPTIONAL)	13
7.	WIRING DIAGRAM	14
8.	AIR FLOW BALANCING	15
9.	TROUBLESHOOTING	16

1. SERVICE

1.1 3D DRAWING

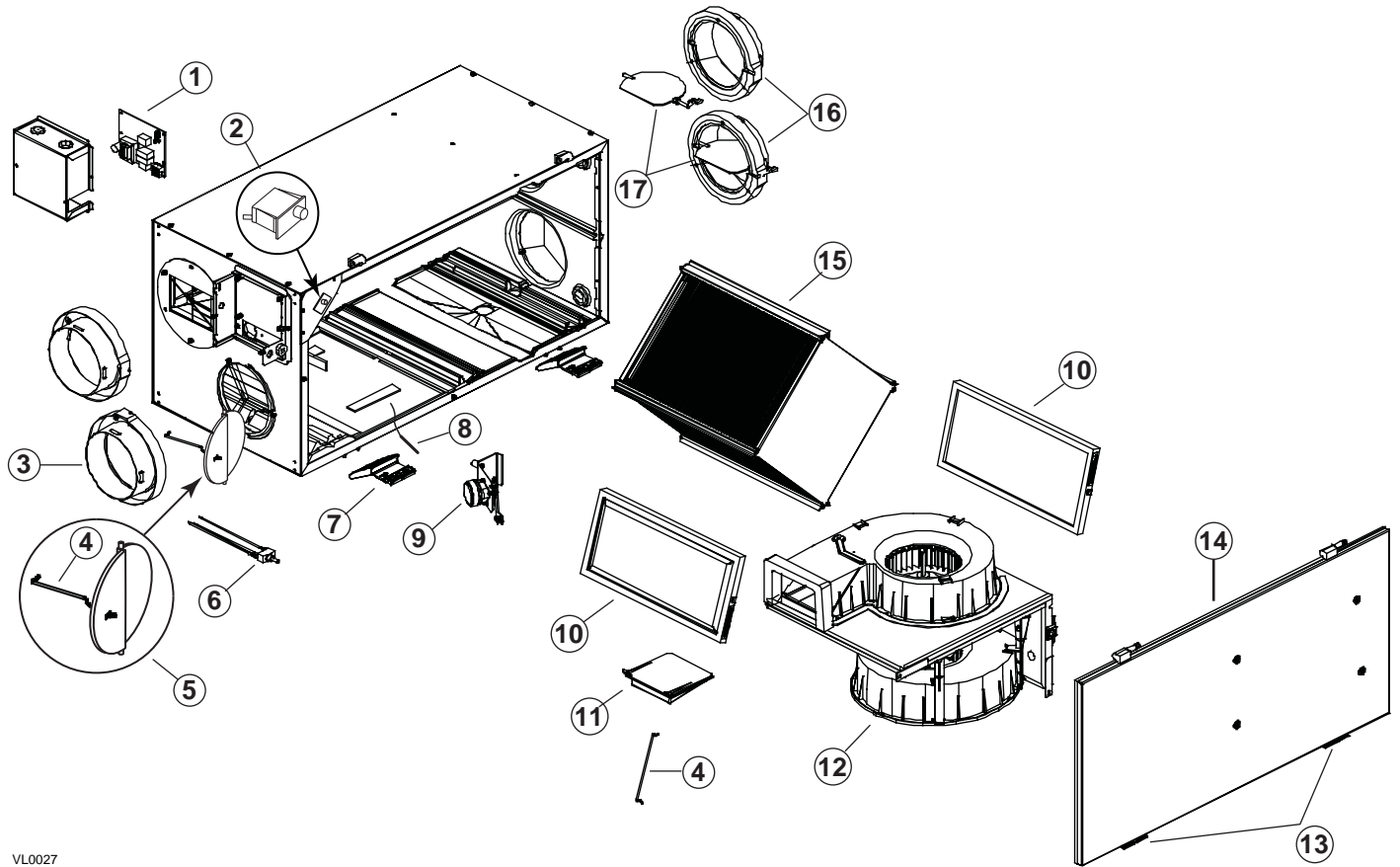

VL0027

1.2 SERVICE PARTS ORDERING CHART

No.	Description	QUATTRO 1.5	QUATTRO 2.0
		43115	45115
1	Electronic Board & Spacers (kit)	16585	16585
2	Door Switch (SPST), E69 10A	01825	01825
3	Double Collar Port #2	02257	02257
4	Damper Rod (kit)	13037	13037
5	Damper #1 (kit)	12454	12454
6	Switch	12664	12664
7	Door Latches & Screws	00886 (2) 00601 (4)	00886 (2) 00601 (4)
8	Thermistor (kit)	12895	12895
9	Damper Actuator Assembly	13734	13734
10	Basic Filter	02300	02300
11	Square Damper (kit)	13033	13033
12	Blower Assembly	16580	16581
13	Door Latches (keeper) & Screws	00887 (2) 00601 (4)	00887 (2) 00601 (4)
14	Door Assembly (including 13)	16584	16584
15	Energy Recovery Core	16582	16582
16	Balancing Double Collar Port	02256	02256
17	Balancing Damper	02253	02253

Please take note that parts not listed are not available; those parts require assembly knowledge that only manufacturer can guarantee.

TO ORDER PARTS: CONTACT YOUR LOCAL DISTRIBUTOR.

1. SERVICE (CONT'D)

1.3 TECHNICAL SUPPORT (FOR TECHNICIANS AND/OR CONTRACTORS ONLY)

For assistance, call on weekdays from 8:30 AM to 5:00 PM (Eastern Standard Time).

NOTE: Do not call this number to order parts.

Canada & USA: 1-800-649-0372 (toll-free)

2. TECHNICAL DATA

2.1 AIR DISTRIBUTION

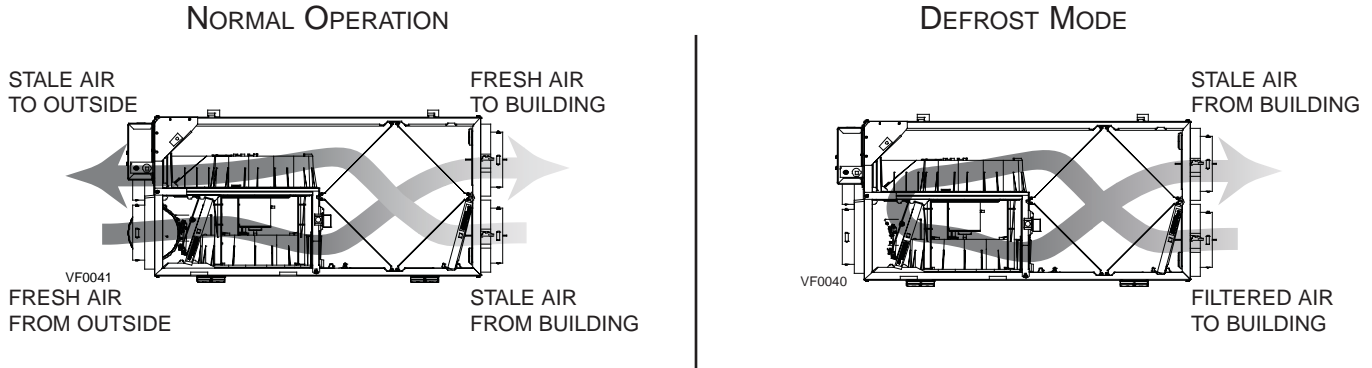

Outside Temperature		Defrost Cycles		Extended Defrost Cycles*	
Celsius (°C)	Fahrenheit (°F)	Defrosting (min.)	Operation time (min.) between each defrost cycle	Defrosting (min.)	Operation time (min.) between each defrost cycle
-5	23	10	60	10	30
-15	5	10	30	10	20
-27	-17	10	20	10	15

*IN A COLD REGION, SET-UP EXTENDED DEFROST BY REMOVING JUMPER JU1-F ON THE CIRCUIT BOARD.

NOTE: THE ERV CONSTRUCTO 1.5 QUATTRO AND ERV CONSTRUCTO 2.0 QUATTRO PERFORMANCE CHARTS ARE LISTED ON THE SPECIFICATION SHEETS OF THESE UNITS. VISIT OUR WEBSITE AT WWW.VENMAR.CA TO ACCESS THOSE DOCUMENTS.

2.2 DIMENSIONS

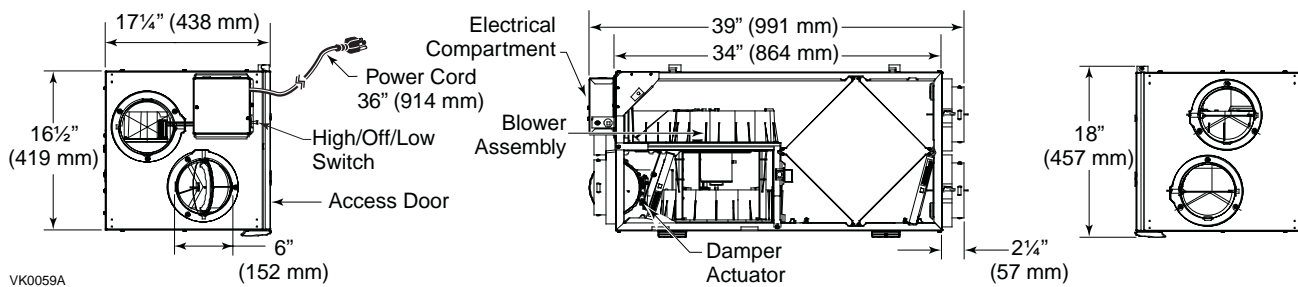

2.3 SPECIFICATIONS

MODEL	QUATTRO 1.5	QUATTRO 2.0
WIDTH	34" (864 MM)	34" (864 MM)
HEIGHT	16 1/2" (419 MM)	16 1/2" (419 MM)
DEPTH	17 1/4" (438 MM)	17 1/4" (438 MM)
WEIGHT	74 LB (34 KG)	76 LB (35 KG)
ELECTRICAL SUPPLY	120 V, 60 Hz	120 V, 60 Hz
POWER CONSUMPTION	115 W	240 W

3. DEFROST SETTING VS GEOGRAPHICAL LOCATION

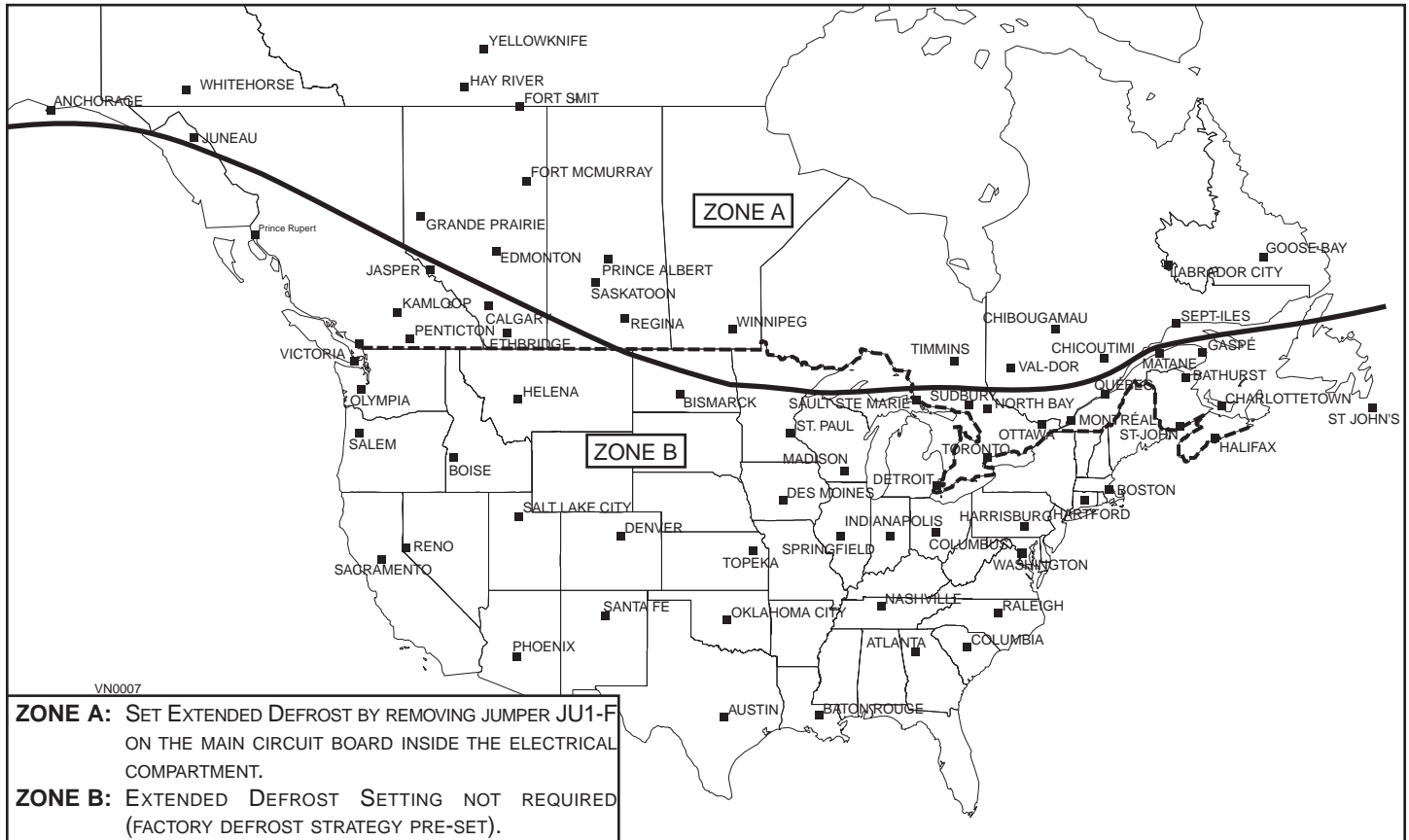

4. TYPICAL INSTALLATION

There are three (3) common installation methods.

4.1 FULLY DUCTED SYSTEM

(Primarily for homes with radiant hot water or electric baseboard heating. See Figure 1.)

Moist, stale air is exhausted from the high humidity areas in the home, such as bathrooms, kitchen and laundry room. Fresh air is supplied to bedrooms and principal living areas.

The use of bathroom fans and range hood is suggested to exhaust stale air.

Homes with more than one level require at least one exhaust register at the highest level.

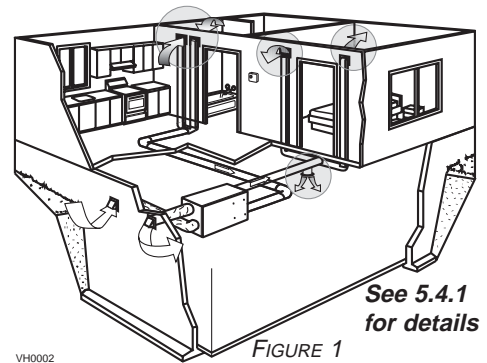

4.2 EXHAUST DUCTED SYSTEM (SOURCE POINT VENTILATION)

(For homes with forced air heating. See Figure 2.)

Moist, stale air is exhausted from the high humidity areas in the home, such as bathrooms, kitchen and laundry room. Fresh air is supplied through the cold air return or the supply duct of the furnace. The use of bathroom fans and range hood is suggested to exhaust stale air.

Homes with more than one level require at least one exhaust register at the highest level.

NOTE: For this type of installation, it is not essential that the furnace blower runs when the unit is in operation, but we recommend it.

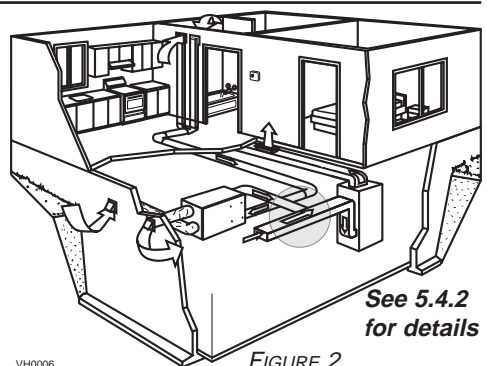

4. TYPICAL INSTALLATION (CONT'D)

4.3 SIMPLIFIED (VOLUME VENTILATION)

(For homes with forced air heating. See Figure 3.)

Fresh air and exhaust air flow through the furnace ducts which simplifies the installation.

The use of bathroom fans and range hood is suggested to exhaust stale air.

NOTE: For this type of installation, the **furnace blower should be running** when the unit is in operation.

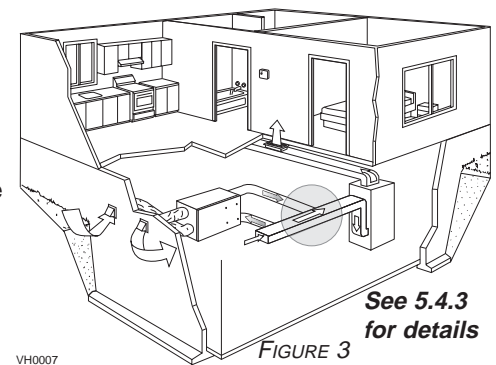

5. INSTALLATION

INSPECT THE CONTENTS OF THE BOX

- Inspect the **exterior of the unit** for shipping damage. Ensure that there is no damage to the door, door latches, door hinges, dampers, duct collars, cabinet, etc.
- Inspect the **interior of the unit** for damage. Ensure that the fan motor assembly, energy recovery core, insulation, dampers and damper actuator are all intact.
- If the unit was damaged during shipping, contact your local distributor. (Claim must be made within 24 hours after delivery.)
- Use checklist included with the unit to ensure that no parts are missing.

5.1 LOCATING AND MOUNTING THE UNIT

Choose an **appropriate location** for the unit:

- Within an area of the house where the temperature is above 10°C/50°F (basement, attic, furnace room, laundry room, etc.).
- Away from living areas (dining room, living room, bedroom), if possible.
- So as to provide easy access to the interior cabinet and to the control panel on the side of the unit.
- Close to an exterior wall, so as to limit the length of the insulated flexible duct to and from the unit.
- Away from hot chimneys, electrical panel and other fire hazards.
- Allow for a power source (standard outlet)

Hang the unit with the 4 chains and springs provided (see Figures 4 and 5).

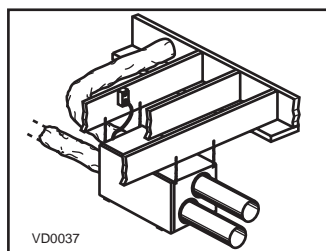

FIGURE 4

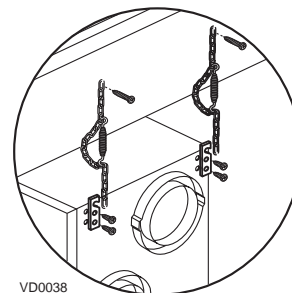

FIGURE 5

CAUTION
Make sure the unit is level, with 1/8" (3 mm) tilt backwards (see Figure 6).

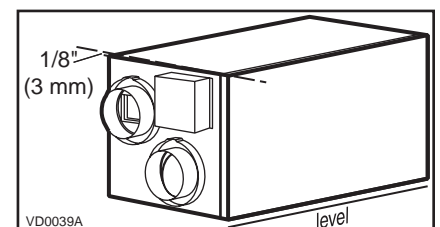

FIGURE 6

5. INSTALLATION (CONT'D)

5.2 PLANNING THE DUCTWORK

- Follow the instructions in Section 5.3 to determine the appropriate duct diameters for your system.
- Keep it simple. Plan for a minimum number of bends and joints. Keep the length of insulated duct to a minimum.
- Do not use wall cavities as ducts. Do not use branch lines smaller than 4" (102 mm) Ø.
- Do not ventilate crawl spaces or cold rooms. Do not attempt to recover the exhaust air from a dryer or a range hood. This would cause clogging of the recovery core. Use sheet metal for the kitchen exhaust duct.
- Be sure to plan for at least one exhaust register on the highest lived-in level of the house if it has 2 floors or more.

5.3 CALCULATING THE DUCT SIZE

Use the table below to ensure that the ducts you intend to install will be carrying air flows at or under the recommended values. Avoid installing ducts that will have to carry air flows near the maximum values and never install a duct if its air flow exceeds the maximum value.

Duct Diameter	Recommended Air Flow			Maximum Air Flow		
	cfm	l/s	m ³ /h	cfm	l/s	m ³ /h
4" (102 mm)	40 cfm	19 l/s	68 m ³ /h	60 cfm	28 l/s	102 m ³ /h
5" (127 mm)	75 cfm	35 l/s	127 m ³ /h	110 cfm	52 l/s	187 m ³ /h
6" (152 mm)	120 cfm	57 l/s	204 m ³ /h	180 cfm	85 l/s	306 m ³ /h
7" (178 mm)	185 cfm	87 l/s	314 m ³ /h	270 cfm	127 l/s	459 m ³ /h
8" (203 mm)	260 cfm	123 l/s	442 m ³ /h	380 cfm	179 l/s	645 m ³ /h

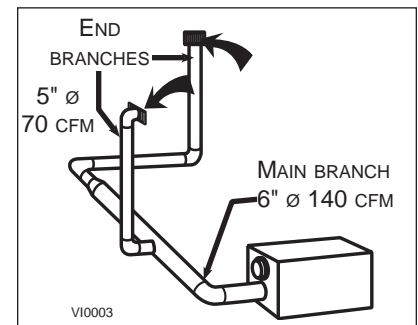

FIGURE 7

NOTE: Examples 5.3.1 and 5.3.2 use imperial measures. The same calculation applies to metric measures.

5.3.1 Example of calculation:

Problem: My installation requires two exhaust registers (one for the kitchen, one for the bathroom). I will connect these registers to a main duct which will connect to the unit (high speed performance value of 140 cfm). What size of duct should I use for the main exhaust duct and for the two end branches leading to the registers? (See Figure 7.)

Solution: Simplified method. (For a more detailed method of calculating duct size refer to the ASHRAE or HRAI HANDBOOK).

Main duct: Table above indicates a 6" Ø duct: recommended air flow: 120 cfm; maximum air flow: 180 cfm. The high speed air flow of 140 cfm is close enough to the recommended value (120) and far enough from the maximum value (180). Therefore a 6" Ø duct or larger is an appropriate choice for the main exhaust duct.

End branches: Each end branch will have to transport air flow of 70 cfm (140 divided by 2). Table above indicates a 5" Ø duct: recommended air flow: 75 cfm; maximum air flow: 110 cfm. The high speed air flow of 70 cfm is close enough to the recommended value (75) and far enough from the maximum value (110). Therefore, a 5" Ø duct or larger is an appropriate choice for the 2 end branches.

NOTE: A 4" Ø duct would have been too small because the maximum acceptable value for a 4" Ø duct is 60 cfm.

5.3.2 Example of a design for a fully ducted system for a unit having 222 cfm high speed performance (See Figure 8).

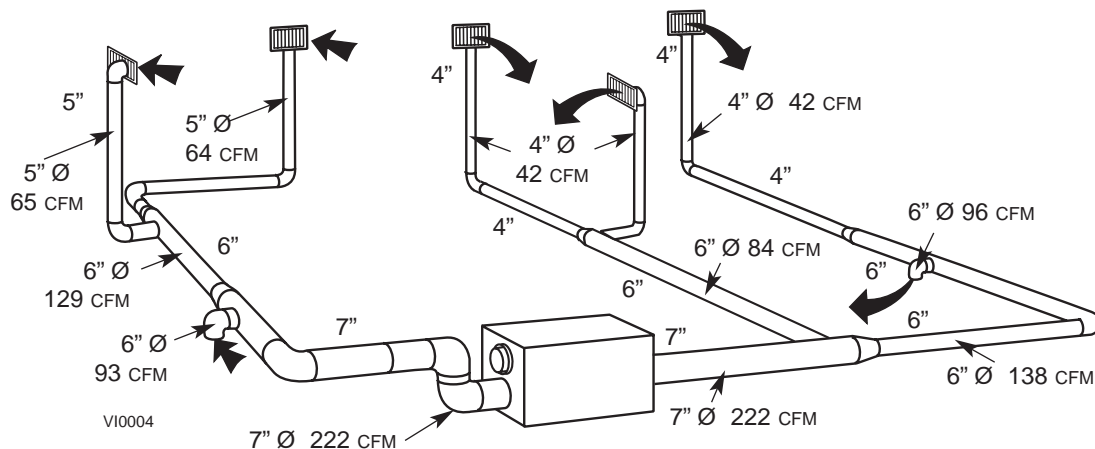

FIGURE 8

5. INSTALLATION (CONT'D)

5.4 INSTALLING THE DUCTWORK AND REGISTERS

⚠ WARNING

Never install a stale air exhaust register in a room where there is a combustion device, such as a gas furnace, a gas water heater or a fireplace.

5.4.1 Fully Ducted System (as illustrated in Section 4.1)

Stale air exhaust ductwork:

- Install registers in areas where contaminants are produced: kitchen, bathrooms, laundry room, etc.
- Install registers 6 to 12 inches (152 to 305 mm) from the ceiling on an interior wall OR install them in the ceiling.
- Install the kitchen register at least 4 feet (1.2 m) from the range.
- If possible, measure the velocity of the air flowing through the registers. If the velocity is higher than 400 ft./min. (122 m/min.), then the register type is too small. Replace with a larger one.

Fresh air distribution ductwork:

- Install registers in bedrooms, dining room, living room and basement.
- Install registers either in the ceiling or high on the walls with air flow directed towards the ceiling. (The cooler air will then cross the upper part of the room and mix with room air before descending to occupant level.)
- If a register must be floor installed, direct the air flow up the wall.

5.4.2 Exhaust Ducted System (Source Point Ventilation) (as illustrated in Section 4.2)

Stale air exhaust ductwork: (same as for Fully Ducted System described in 5.4.1)

Fresh air distribution:

⚠ WARNING

When performing duct connection to the furnace, installation must be done in accordance with all applicable codes and standards. Please refer to your local building code.

CAUTION

When performing duct connection to the furnace supply duct, this duct must be sized to support the additional airflow produced by the ERV. Also, use a steel duct. It is recommended that the ERV is running when the furnace is in operation in order to prevent backdrafting inside ERV.

There are two methods for connecting the unit to the furnace:

Method 1: supply side connection

- Cut an opening into the furnace supply duct at least 18 inches (0.5 m) from the furnace.
- Connect this opening to the fresh air distribution port of the ERV (use **steel duct**, see Figure 9).
- Make sure that the ERV duct forms an elbow inside the furnace ductwork.
- If desired, interlock (synchronize) the furnace blower operation with the ERV operation. (See Section 6.4).

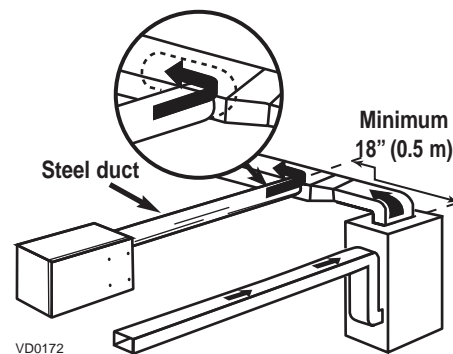

Method 2: return side connection

- Cut an opening into the furnace return duct not less than 10 feet (3.1m) from the furnace (A+B).
- Connect this opening to the fresh air distribution port of the ERV (see Figure 10).

NOTE: For Method 2, it is not essential that the furnace blower runs when the unit is in operation, but we recommend it. If desired, synchronize the furnace blower operation with the ERV operation (see Section 6.4).

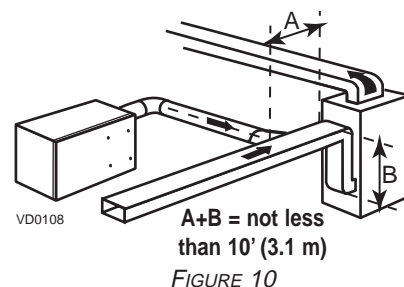

5. INSTALLATION (CONT'D)

5.4 INSTALLING THE DUCTWORK AND REGISTERS (CONT'D)

5.4.3 Simplified Installation (Volume Ventilation) (as illustrated in Section 4.3)

WARNING

When performing duct connection to the furnace, installation must be done in accordance with all applicable codes and standards. Please refer to your local building code.

CAUTION

When performing duct connection to the furnace ducts (Method 1), these ducts must be sized to support the additional airflow produced by the ERV. Also, the supply duct must be a steel duct. It is recommended that the ERV runs when the furnace is in operation in order to prevent backdrafting inside ERV.

There are two methods (Figures 11 and 12) for connecting the unit to the furnace:

Method 1: return-supply

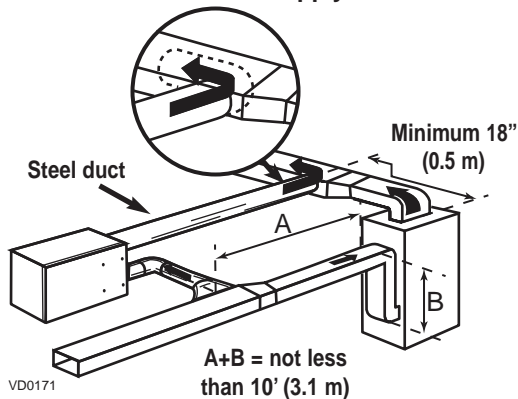

FIGURE 11

Method 2: return-return

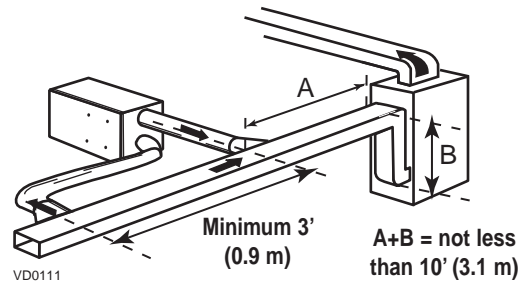

FIGURE 12

Stale air intake:

- Cut an opening into the furnace return duct (not less than 10 feet (3.1 m) from the furnace).
- Connect this opening to the stale air intake port on the ERV as shown.

Fresh air distribution: (same instructions as for Method 1 or Method 2, Section 5.4.2).

CAUTION

If using Method 2, make sure the furnace blower operation is synchronized with the unit operation! See Section 6.4.

For Method 2 (return-return) make sure there is a distance of at least 3 feet (0.9 m) between the 2 connections to the furnace.

NOTE: For Method 1, it is not essential to synchronize the furnace blower operation with the unit operation, but we recommend it.

5. INSTALLATION (CONT'D)

5.5 CONNECTING THE DUCT TO THE UNIT

Insulated flexible duct

Use the following procedure to connect the insulated flexible duct to the ports on the unit (exhaust to outside and fresh air from outside).

- Pull back the insulation to expose the flexible duct.
- Connect the interior flexible duct to the port using a duct tie.
- Carefully seal the connection with duct tape.
- Pull the insulation over the joint and tuck it between the inner and outer rings of the double collar.
- Pull the vapor barrier over the insulation and over the outer ring of the double collar.
- Apply duct tape to the joint making an airtight seal. Avoid compressing the insulation when you pull the tape tightly around the joint. Compressed insulation loses its R value and causes water dripping due to condensation on the exterior surface of the duct.

CAUTION

Make sure that the vapor barrier on the insulated ducts does not tear during installation to avoid condensation within the duct.

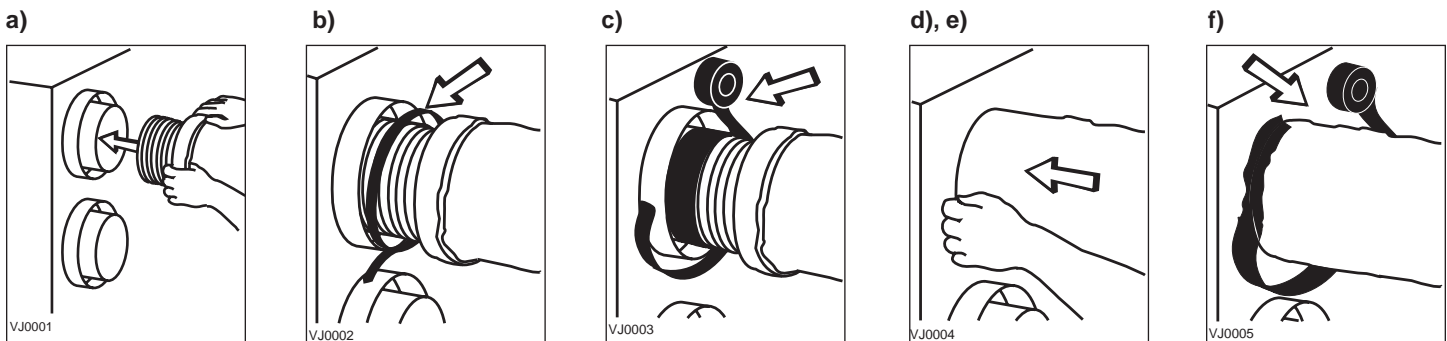

Rigid duct:

Use duct tape to connect the rigid ducts to the ports.

Make sure that the 2 balancing dampers are left in a fully open position before connecting the ducts to these ports (fresh air distribution port and stale air exhaust port as shown on Figure 13).

CAUTION

Do not use screws to connect rigid ducts to the ports.

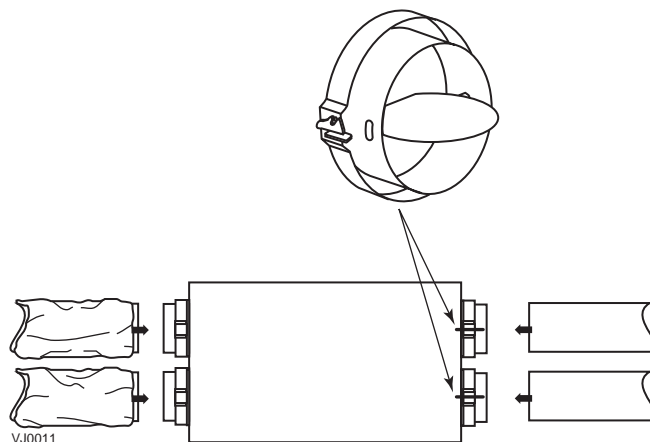

FIGURE 13

5. INSTALLATION (CONT'D)

5.6 INSTALLING THE EXTERIOR HOODS

Choose an appropriate location for installing the exterior hoods:

- a minimum distance of 6 feet (1.8 m) between the hoods is necessary to avoid cross-contamination
- a minimum distance of 18 inches (457 mm) from the ground is required

Make sure the intake hood is at least 6 feet (1.8 m) away from any of the following:

- dryer exhaust, high efficiency furnace vent, central vacuum vent
- gas meter exhaust, gas barbecue-grill
- any exhaust from a combustion source
- garbage bin and any other source of contamination

Refer to Figure 14 for connecting the insulated duct to the hoods. Place the "FRESH AIR INTAKE" sticker, provided in the installation kit, on corresponding hood. An "Anti-Gust Intake Hood" should be installed in regions where a lot of snow is expected to fall.

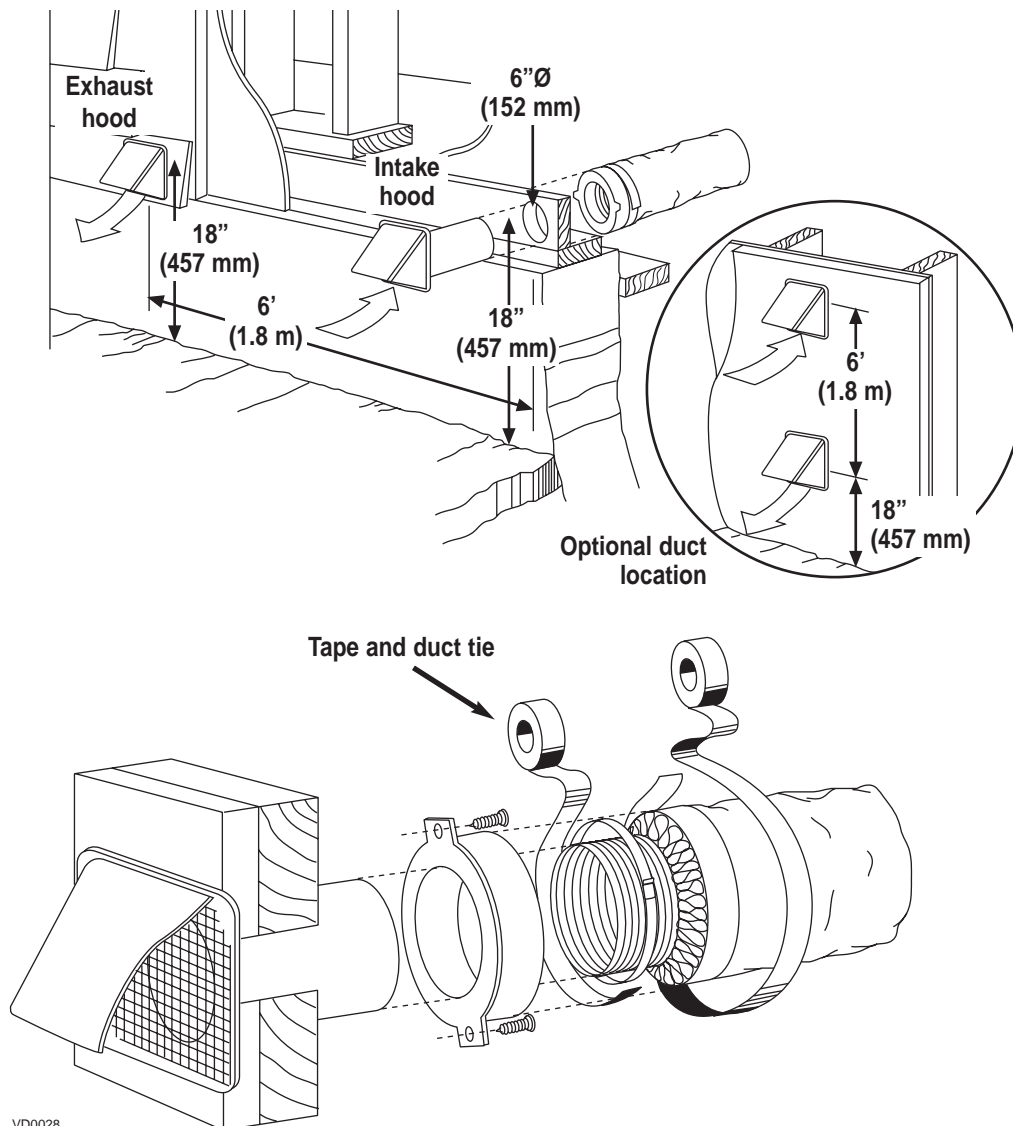

FIGURE 14

6. CONTROLS

6.1 MAIN CONTROLS

6.1.1 3-Position Switch

Location: Located on the side of the unit.

Purpose: To adjust air supply.

How to operate on a daily basis

- Select LOW SPEED for normal daily operation.
- Select HIGH SPEED for excess pollutants and humidity (parties, odors, smoke, etc.)

How to turn off the unit:

Set switch to the REMOTE position.

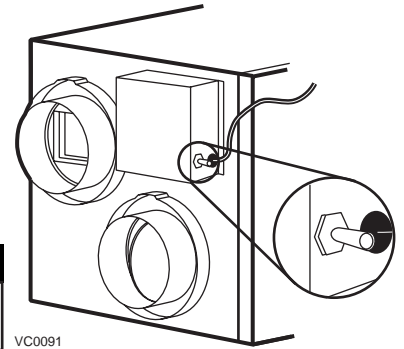

VC0091

⚠ WARNING

Optional controls can still activate the unit, even when in REMOTE position. You must, therefore, unplug the unit to be absolutely sure it is off.

6.1.2 Lite-Touch Constructo

Location: Located in the busiest area of the house.

Purpose: To adjust air supply and select the desired indoor humidity level.

Activate the push-button. The color of the indicator shows the unit operating mode.

Color	Mode	Suggested Use
Green	Intermittent	Select this mode when you are away from the house for a few days. Also, when you deem the inside air is too dry in heating season, or too humid in cooling season. In this mode, the unit is OFF for 40 minutes per hour and ventilates at minimum speed the remaining 20 minutes of the hour.
Yellow	Min. Speed Ventilation	For normal daily operation.
Red	Max. Speed Ventilation	For excess pollutants and humidity (parties, odors, smoke, etc.).

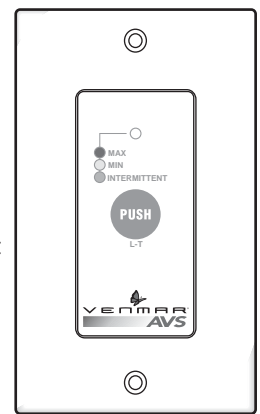

VC0075

6.2 AUXILIARY CONTROLS

6.2.1 20-Minute Lighted Push-Button

Location: Located in the bathroom or in other locations where temporary humidity excess or pollutants are present.

Purpose: To eliminate excess humidity produced by showers or other periodic activities generating pollutants.

Press once to activate the push-button. The unit will operate at high speed for 20 minutes and the indicator will light up. To stop activation before the end of the 20-minute cycle, push one more time. The unit will return to its previous setting.

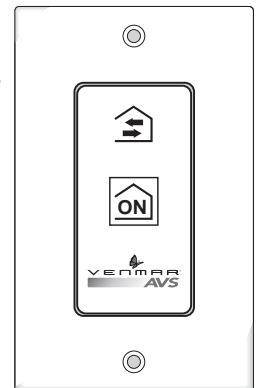

VC0082

6.2.2 60-Minute Mechanical Timer

Location: Located in the bathroom or in other locations where temporary humidity excess or pollutants are present.

Purpose: To eliminate excess humidity produced by showers or other periodic activities generating pollutants.

This control activates the system to operate at high speed for periods varying from 10 to 60 minutes.

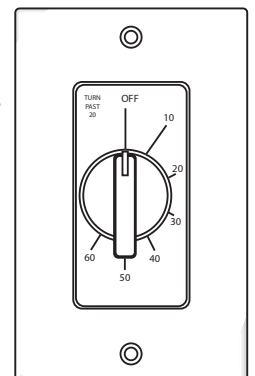

VC0017

6. CONTROLS (CONT'D)

6.3 ELECTRICAL CONNECTION TO LITE-TOUCH CONSTRUCTO AND AUXILIARY CONTROLS

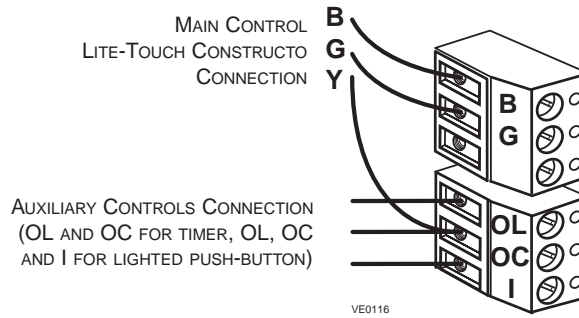

6.4 ELECTRICAL CONNECTION TO THE FURNACE (OPTIONAL)

⚠ WARNING

Never connect a 120-volt AC circuit to the terminals of the furnace interlock (standard wiring). Only use the low-voltage class 2 circuit of the furnace blower control.

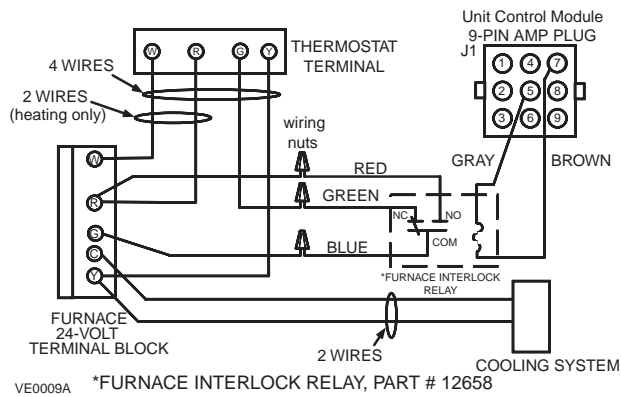

Models: ERV Constructo 1.5 Quattro ERV Constructo 2.0 Quattro

Connection

Logic

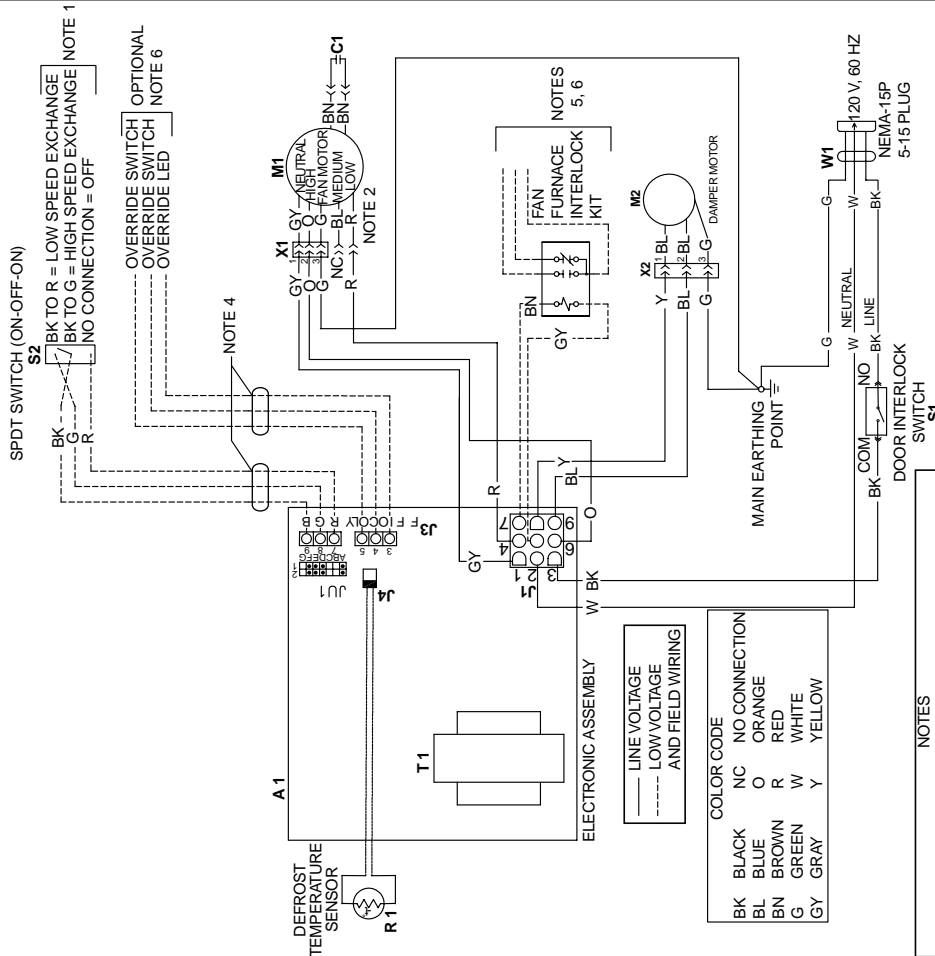

- NOTES**
- OPTIONAL CONTROLS AVAILABLE.
 - FACTORY SET WIRING FOR BLOWER SPEED SELECTION IS HIGH AND LOW. MEDIUM SPEED CAN BE SELECTED INSTEAD OF LOW SPEED. DISCONNECT RED WIRE FROM THE MOTOR RED TAP AND CONNECT TO THE MOTOR BLUE TAP.
 - IF ANY OF THE ORIGINAL WIRE AS SUPPLIED, MUST BE REPLACED, USE THE SAME OR EQUIVALENT WIRE.
 - USE FACTORY-SUPPLIED PROTECTIVE TUBING.
 - FIELD INSTALLED OPTION: USE ONLY FACTORY-SUPPLIED KIT NO. 12658. FURNACE FAN CIRCUIT MUST BE CLASS 2 CIRCUIT ONLY.
 - FIELD WIRING MUST COMPLY WITH APPLICABLE CODES, ORDINANCES AND REGULATIONS.

VE0141A

7. WIRING DIAGRAM

WARNING

Risk of electrical shocks. Before performing any maintenance or servicing, always disconnect the unit from its power source.

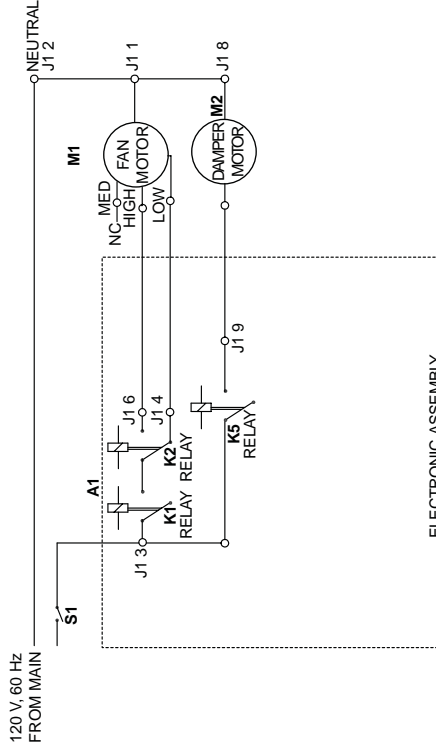

JUMPERS TABLE

JU1A	JU1B	JU1C	JU1D	JU1E	JU1F	JU1G
IN	OUT	OUT	OUT	IN	IN	OUT
OUT	OUT	OUT	OUT	IN	IN	OUT
OUT	OUT	OUT	OUT	OUT	OUT	OUT

MODEL

2	1
A	B
C	D
E	F
G	

DEFROST TIME (DEFROST/VENTILATION) MINUTES

23°F	5°F	-17°F
-5°C	-15°C	-27°C

MODEL

JU1A	JU1B	JU1C	JU1D	JU1E	JU1F	JU1G
IN	OUT	OUT	OUT	IN	IN	OUT
OUT	OUT	OUT	OUT	IN	IN	OUT
OUT	OUT	OUT	OUT	OUT	OUT	OUT

FUNCTION TABLE

MODE	K1	K2	K5
Intermittent	0	0	1
Exchange Low	1	0	0
Exchange High	1	1	0
Defrost Cycle	1	1	1
Off	0	0	1

0 = Relay coil is de-energized
1 = Relay coil is energized

8. AIR FLOW BALANCING

WHAT YOU NEED TO BALANCE THE UNIT

- A magnehelic gauge capable of measuring 0 to 0.5 inch of water (0 to 125 Pa) and 2 plastic tubes.
- The balancing chart provided with the unit.

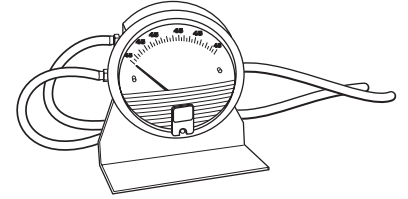

PRELIMINARY STAGES TO BALANCE THE UNIT

- Seal all the unit ductwork with tape. Close all windows and doors.
- Turn off all exhaust devices such as range hood, dryer and bathroom fans.
- Make sure the balancing dampers are fully open.
- Make sure all filters are clean (if it is not the first time you balance the unit).

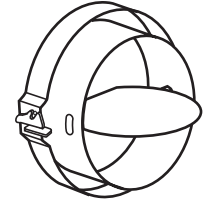

BALANCING PROCEDURE

1. Set the unit to high speed.

Make sure that the furnace blower is ON if the installation is in any way connected to the ductwork of the cold air return. If not, leave furnace blower OFF. If the outside temperature is below 0°C/32°F, make sure the unit is not running in defrost while balancing. (By waiting 10 minutes after plugging the unit in, you are assured that the unit is not in a defrost cycle.)

2. Place the magnehelic gauge on a level surface and adjust it to zero.

3. Connect tubing from gauge to EXHAUST air flow pressure taps (see diagram).

Be sure to connect the tubes to their appropriate *high/low* fittings. If the gauge drops below zero, reverse the tubing connections.

NOTE: It is suggested to start with the exhaust air flow reading because the exhaust has typically more restrictions than the fresh air, especially in cases of fully ducted installations or source point ventilation. Place the magnehelic gauge upright and level. Record equivalent AIR FLOW of the reading according to the balancing chart.

4. Move tubing to FRESH air flow pressure taps (see diagram). Adjust the fresh air balancing damper until the fresh air flow is approximately the same as the EXHAUST air flow. If fresh air flow is less than exhaust air flow, then go back and adjust the exhaust balancing damper to equal the fresh air flow.

5. Secure both dampers in place with tape or fastening screw.

6. Write the required air flow information on a label and stick it near the unit for future reference (date, maximum speed air flows, your name, phone number and business address).

NOTE: The unit is considered balanced even if there is a difference of +/- 10 cfm or +/- 5 L/s or 17 m³/h between the two air flows.

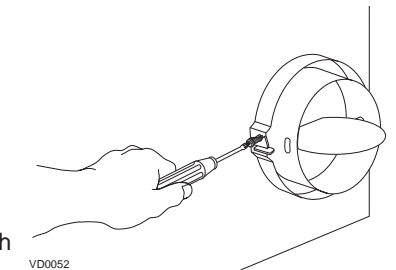
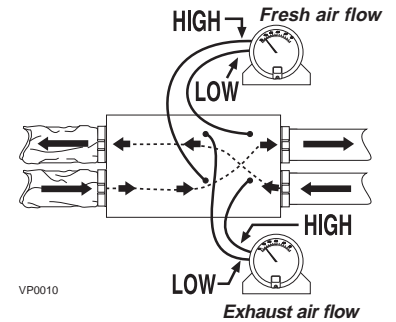

9. TROUBLESHOOTING

NOTE: Be sure to unplug and inspect the unit before proceeding with these steps.
Start with point 1, then point 2 and so on.

Start-up troubleshooting:

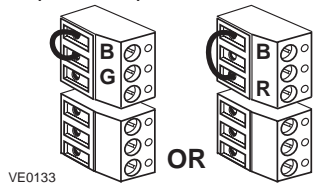
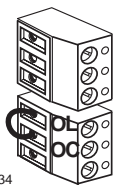
Problems	Possible causes	You should try this
1. Unit does not work.	<ul style="list-style-type: none"> • Erratic operation of the electronic circuit. • The breaker in the electrical panel may be tripped. • The door switch may be defective. • The circuit board may be defective. 	<ul style="list-style-type: none"> • Unplug the unit. Wait for 30 seconds. Plug it back in. • Reset breaker. If it trips again, unplug the unit and call an electrician. • Using a multimeter, check for power across the switch (the door switch must be pushed in for this test). If there is no power, replace the switch.
	<ul style="list-style-type: none"> • The fan motor may be defective. • The 9-pin connector may have a loose connection. 	<ul style="list-style-type: none"> • Jump BLACK and GREEN terminals and check if the motor runs on high speed (or jump BLACK and RED terminals and check if the motor runs on low speed) and the damper opens, the circuit board is not defective. (The door switch must be pushed in for this test.) Replace the board if no voltage is detected. • Unplug the unit and disconnect the fan motor (4 wires). Supply 120 V directly to the GREY and ORANGE wires of the fan motor. Replace the motor if not working. • Unplug the unit and check to make sure all the crimp connections are sound. Check the fan motor and the damper actuator connections as well.
		
2. The damper actuator doesn't work.	<ul style="list-style-type: none"> • The 9-pin connector may have a loose connection. • The damper actuator may be defective. • The circuit board may be defective. 	<ul style="list-style-type: none"> • Unplug the unit and check to make sure all the crimp connections are secured. Check the damper actuator connections as well. • Feed 120 V directly to the damper actuator. If the problem persists, replace the damper actuator. • Replace the circuit board if the problem is not solved by the above.
3. The wall control will not function.	<ul style="list-style-type: none"> • The wire in the wall OR the wall control may be defective. • The wires may be in reverse position. • The wires may be broken. • There may be a short-circuit. 	<ul style="list-style-type: none"> • Remove the wall control and test it right beside the unit using another shorter wire. If the wall control works there, change the wire. If it doesn't, change the wall control. • Ensure that the color-coded wires have been connected to their appropriate places. • Inspect every wire and replace any damaged ones. • With the help of a multimeter, check for continuity.
4. The 20-minute lighted push-button switch doesn't work OR its indicator light doesn't stay on.	<ul style="list-style-type: none"> • Switch may be defective. • The wires may be defective OR may not be connected properly. 	<ul style="list-style-type: none"> • Jump the OL and OC terminals. If the unit switches to high speed, then the wires are not the problem. Replace the push-button. • Ensure that the color-coded wires have been connected to their appropriate places.
		
5. The defrost cycle doesn't work (the fresh air duct is frozen OR the fresh air distributed is very cold).	<ul style="list-style-type: none"> • Ice deposits may be hindering the damper operation. • The damper rod or the port damper itself may be broken. • The damper actuator may be defective. • The circuit board may be defective. • The thermistor may be defective. 	<ul style="list-style-type: none"> • Remove the ice. • Inspect these parts and replace if necessary. • Plug in the unit and select «OFF». Press the door switch and see if the port damper closes. If it doesn't close, feed 120 V directly to the damper actuator. If the port damper still doesn't close, replace the damper actuator. • Unplug the unit. Unplug the defrost sensor wire (see J4 on electrical diagram). Plug the unit back in. Select "MIN" and make sure the unit is adjusted for low-speed operation. Wait 3 minutes. The unit should switch to high speed and the damper at the fresh air intake port should close (defrost mode). If this doesn't happen, then replace the circuit board. • If the defrost mode works well after disconnecting the thermistor wire (above test), then this means the thermistor is probably defective. You should replace it.